

Classroom Audio Systems

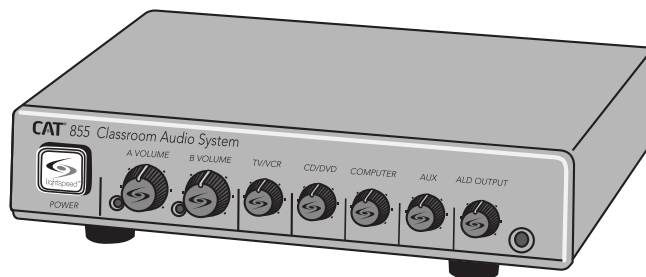

Cat 855



Cat 885



IMPORTANT SAFETY INSTRUCTIONS

1. Read these instructions.
2. Keep these instructions.
3. Heed all warnings.
4. Follow all instructions.
5. Do not use the apparatus near water.
6. Clean only with dry cloth.
7. Do not block any ventilation openings. Install in accordance with the manufacturer's instructions.
8. Do not install near any heat sources such as radiators, heat registers, stoves, or other apparatus (including amplifiers) that produce heat.
9. Do not defeat the safety purpose of the polarized or grounding-type plug. A polarized plug has two blades with one wider than the other. A grounding-type plug has two blades and a third grounding prong. The wide blade or the third prong is provided for your safety. If the provided plug does not fit into your outlet, consult an electrician for replacement of the obsolete outlet.
10. Protect the power cord from being walked on or pinched particularly at plugs, convenience receptacles, and the point where they exit from the apparatus.
11. Only use attachments/ accessories specified by the manufacturer.
12. Use only with a cart, stand, tripod, bracket or table specified by the manufacturer, or sold with the apparatus. When a cart is used, use caution when moving the cart/apparatus combination to avoid injury from tip-over. 
13. Unplug this apparatus during lightning storms or when unused for long periods of time.
14. Refer all servicing to qualified service personnel. Servicing is required when the apparatus has been damaged in any way, such as power-supply cord or plug is damaged, liquid has been spilled or objects have fallen into the apparatus, the apparatus has been exposed to rain or moisture, does not operate normally, or has been dropped.
15. When the mains plug or appliance coupler is used as the disconnect device, it shall remain readily operable.
16. Please keep the unit in a good ventilation environment.
17. **WARNING:** To reduce the risk of fire or electric shock, do not expose this apparatus to rain or moisture.
18. Apparatus shall not be exposed to dripping or splashing and no objects filled with liquids, such as vases, shall be placed on the apparatus.
19. **Warning -** battery pack shall not be exposed to excessive heat such as sunshine, fire or the like.

TABLE OF CONTENTS

SECTION 1:	2	Important Safety Instructions
Overview	4	System Components and Unpacking
SECTION 2:	8	1. Location of the Amplifier
Installation Planning	9	2. Installation of Amplifier Wall Bracket 800WB
	11	3. Installation of Amplifier Wall Bracket 855WB
SECTION 3:	12	ISR Sensor/Receiver Location & Installation
ISR Sensor/Receiver	13	1. ISR Sensor/Receiver Installation
	15	2. ISR Connection to Amplifier
	16	3. Connecting the Power Supply
SECTION 4:	17	TCQ Multimedia Ceiling Speaker Installation Instructions
Speaker Location & Installation	23	Optional Conduit Connection for TCQ
	24	DRQ Ceiling Speaker Installation Instructions
	27	WMQ Wall Speaker Installation Instructions
	30	4JS Ceiling Speaker Installation Instructions (Plenum Rated)
	35	Connecting Wire to Amplifier
SECTION 5:	36	1. Charging the Redmike and Redmike VC
Set Up & Integration	38	2. Operating the Redmike
	39	3. Charging the Redmike Share
	40	4. Operating the Redmike Share
	41	5. Audio Integration
SECTION 6:	42	1. Pagefirst Installation for 855/885
Optional Equipment	44	2. Optional iRMC setup
	46	3. Multiple Sensor Installation for Large Room Applications
SECTION 7:	48	Common Problems and Solutions
Troubleshooting		

SECTION 1:

OVERVIEW

SYSTEM COMPONENTS AND UNPACKING

The standard configuration of the Cat 800 system will contain:

Cat 855 Amplifier

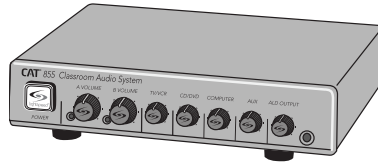

or

Cat 885 Amplifier

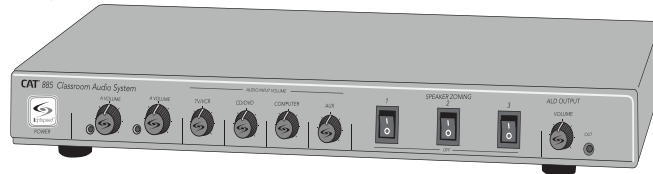

Amplifier Power Supply

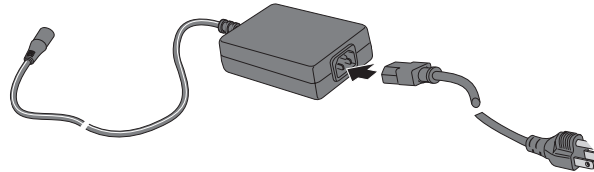

ISR Infrared Sensor/ Receiver and Cable

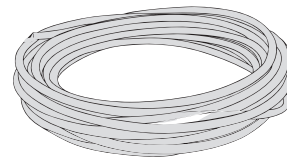
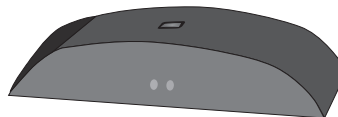

SYSTEM COMPONENTS AND UNPACKING CONT'D

Redmike®
Classroom
Microphone



Cradle Charger and
Power Supply

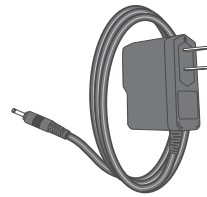
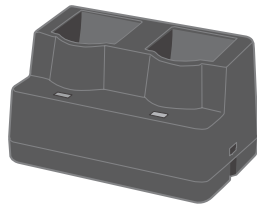

Wall Bracket for Cat
855 Amplifier Only

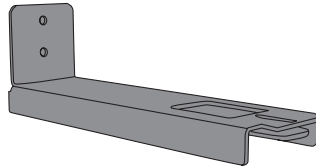

SYSTEM COMPONENTS AND UNPACKING CONT'D

Speakers

Systems can be configured with a variety of different speaker types, including the following:

TCQ (x 1)

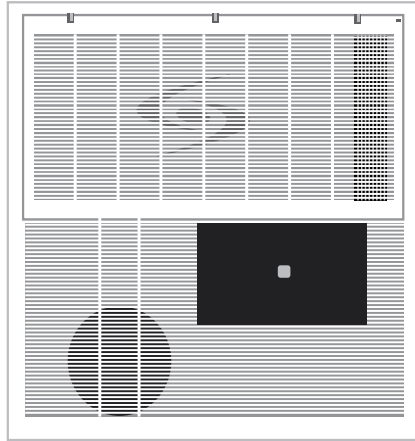

DRQ (x 4)

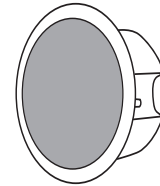

WMQ (x 4)

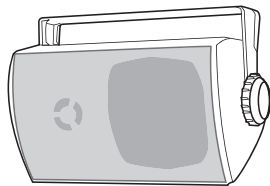

4jCS (x4)
(plenum rated)

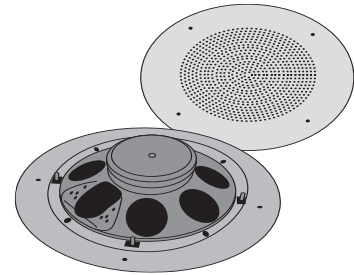

SYSTEM COMPONENTS AND UNPACKING CONT'D

Standard Components for 855 or 885

855 (or)	Audio amplifier/mixer
885	Audio amplifier/mixer
24V-2.5-NA	24V/2.5A power supply for 855/885 in U.S. and Canada
24V-2.5- <u> </u>	24V/2.5A power supply for 855/885, specify country
ISR	Infrared sensor/receiver with mounting bracket
CA-P5E50	50' plenum-rated Cat5e cable
RMT2	Redmike classroom microphone with battery & lavalier cord
NH2A27	AA NiMH rechargeable sensing battery for Redmike
RMCC	Redmike cradle charger
5V-1.0-NA	5V/1.0A power supply for cradle charger in U.S. and Canada
5V-1.0-INT	5V/1.0A power supply for cradle charger outside U.S. and Canada
855WB	Wall mount bracket for 855 only.
SPEAKERS	As ordered.

7. Troubleshooting

6. Installing Optional Equipment

5. Set Up & Integration

4. Speaker Location & Installation

3. iR Sensor Location & Installation

2. Installation Planning

1. Overview

SECTION 2:

INSTALLATION PLANNING

1. LOCATION OF THE AMPLIFIER

First, find a suitable location to set-up the amplifier. It is best to put the amplifier in a stable location near the other equipment to be used. It can be set in a cabinet, on a tabletop, or mounted on the wall with the optional wall shelf.

Media Cabinet Set-up

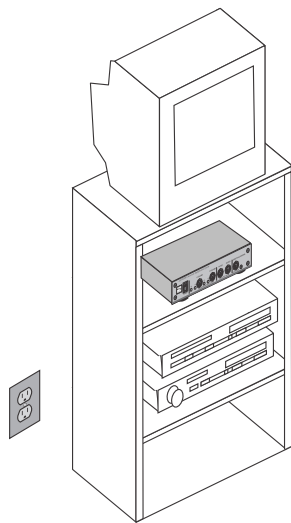

Wall-mount Set-up

The optional Lightspeed wall shelf (part #800WB) is specifically designed to support the Cat 885. The standard Lightspeed wall shelf (part #855WB) is designed to support the Cat 855.

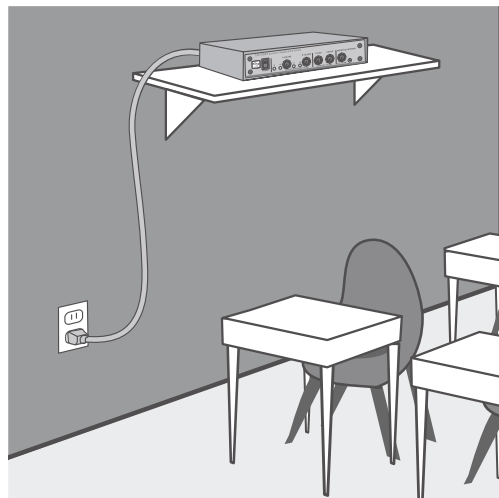

Avoid Separated Set-ups

Components should be housed together. Wires should be routed back directly to the amplifier.

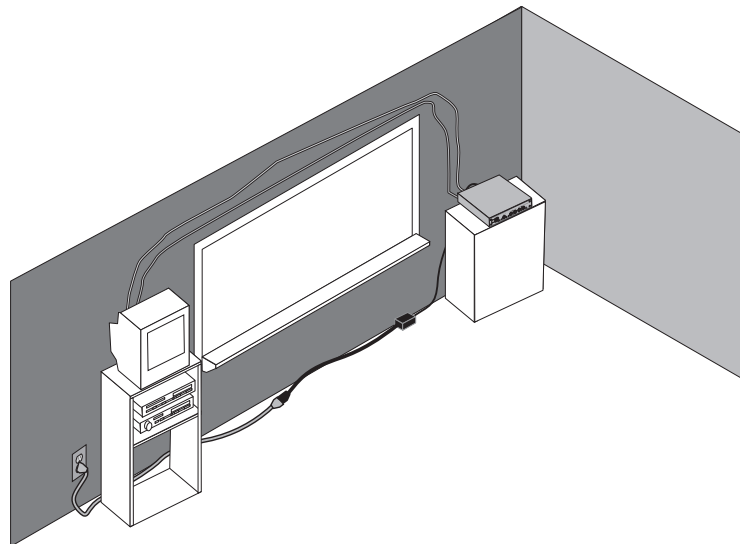

2. INSTALLATION OF AMPLIFIER WALL-MOUNT BRACKET 800WB

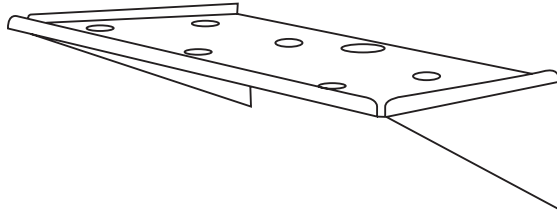

Optional 800WB for wall mounting the Cat 885.

Specifications:

Dimensions (D x W x H): 11" x 20.7" x 5.5"

Weight: 5.15 lbs

Load Capacity: 25 lbs

Designed for: Cat 885

Installation Instructions:

Recommended tools: Screwdriver, hammer, pencil, level

1. Determine the location of the shelf:
 - a. It should be located near a power outlet.
 - b. Height should allow for easy access to front control panel, typically 4-5 feet from the floor.
2. Attach the two brackets to the shelf using the short screws provided.
3. Position shelf on the wall as it is shown in the illustration above.

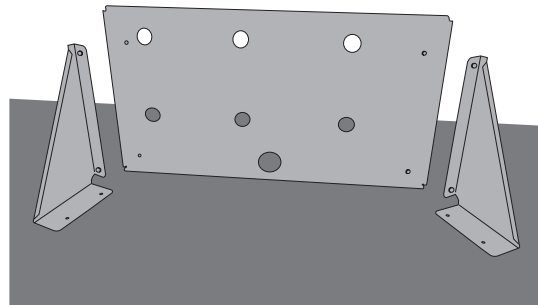

7. Troubleshooting

6. Installing Optional Equipment

5. Set Up & Integration

4. Speaker Location & Installation

3. iR Sensor Location & Installation

2. Installation Planning

1. Overview

2. INSTALLATION OF AMPLIFIER WALL-MOUNT BRACKET 800WB cont'd

4. Use level to determine that the shelf is straight.
5. The back of the shelf (the portion that is flush against the wall) has four mounting holes. Using a pencil, mark the location of the mounting holes onto the wall.
6. With the enclosed hardware, attach the shelf to the wall:
 - a. Attaching to sheetrock or plaster walls:
 - i. Gently screw the self-tapping anchors into the wall at the 4 marked points. If the wall is very hard material (ie. plaster), it may be necessary to drill a pilot hole.
 - ii. Holding the shelf up to the wall, tighten the screws into the anchors until the shelf is snug against the wall.
 - b. Attaching to wood or into wall studs:
 - i. Drill a small pilot hole at the 4 marked points.
 - ii. Holding the shelf up to the wall, drill the screws directly into the wall until the shelf is snug.
7. Place the amplifier on the shelf, inserting the rubber feet on the bottom of the amplifier through the corresponding holes on the shelf.
8. There is room behind the amplifier to place the power supply and to thread the AC cord through the hole in the back.
9. The microphones should be set on the shelf to the side of the amplifier where they can be plugged in for charging. The rolled edge of the shelf will prevent them from sliding off.

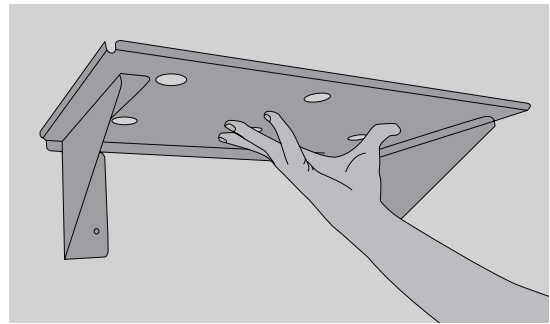

3. INSTALLATION OF AMPLIFIER WALL-MOUNT BRACKET 855WB

The Cat 855 system includes a bracket for optional wall-mounting.

Specifications:

Dimensions:

Wall footprint (H x W): 2.5" x 2.25"

Wall to back of 855: 3.5"

Wall to front of 855: 11.25"

Weight: .65 lbs

Load Capacity: 10 lbs

Designed for: Cat 855

Installation Instructions:

1. Determine the location:
 - a. It should be located near a power outlet.
 - b. Height should allow for access to front control panel, but also be in compliance with building and ADA regulations.
2. Screw the bracket to the wall at the two screw hole points with the included hardware. Attach to a stud when possible; use the drywall mollys when studs are not available.
3. Slide the Cat 855 onto the bracket using the channel on the bottom of the amplifier.
4. Secure the Cat 855 to the bracket by tightening the screw on the bottom.
5. Now that the Cat 855 is secure, it can be slowly pulled out and pivoted for better access to the back panel. Push the Cat 855 back in, to lock into place.
6. The power supply can be set on the back of the bracket and secured with ties if desired.

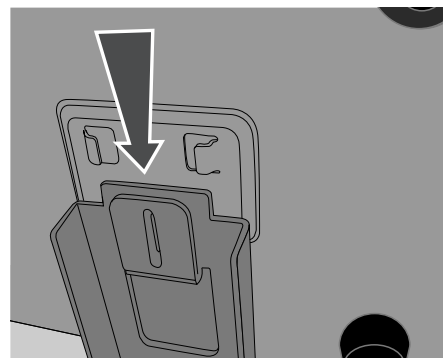
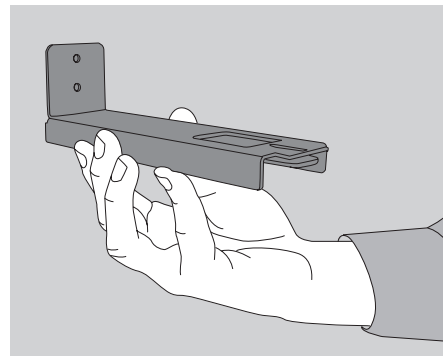

7. Troubleshooting

6. Installing Optional Equipment

5. Set Up & Integration

4. Speaker Location & Installation

3. iR Sensor Location & Installation

2. Installation Planning

1. Overview

SECTION 3:

ISR SENSOR/RECEIVER LOCATION & INSTALLATION

Sensor location is very important for optimum performance of the Classroom Audio System.

- **BEST:** On the ceiling at or near the middle of the classroom.
- **GOOD:** High and centered on the long wall.
- **AVOID:** Locations in corners, on walls at heights lower than 7 feet, or in places where the line of sight is or could be obstructed.

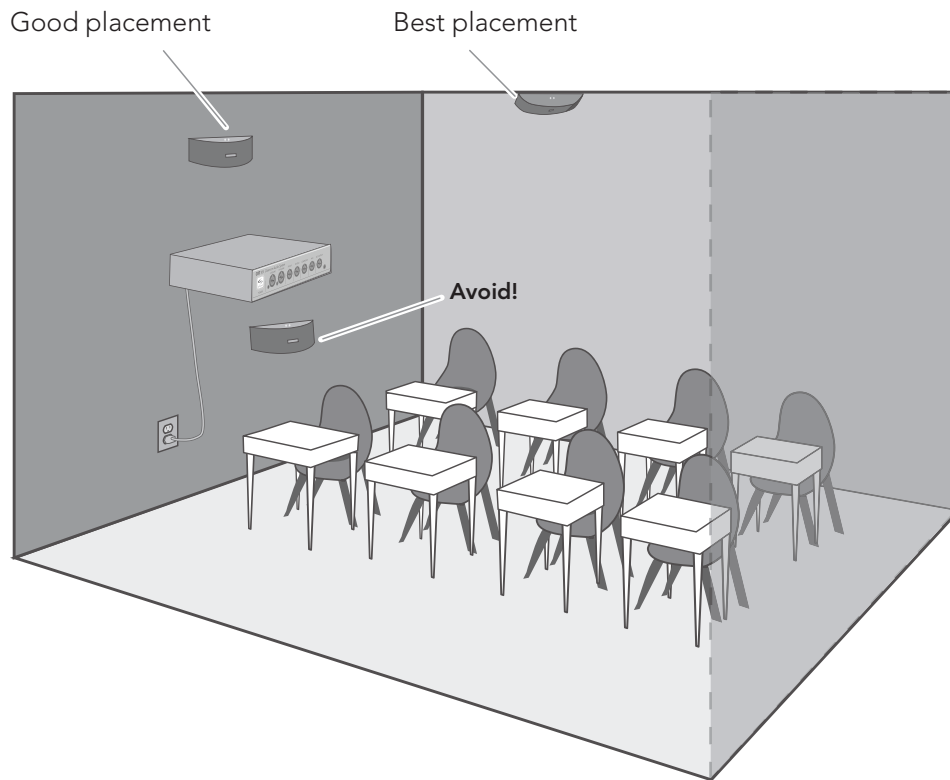

Conduit is Recommended

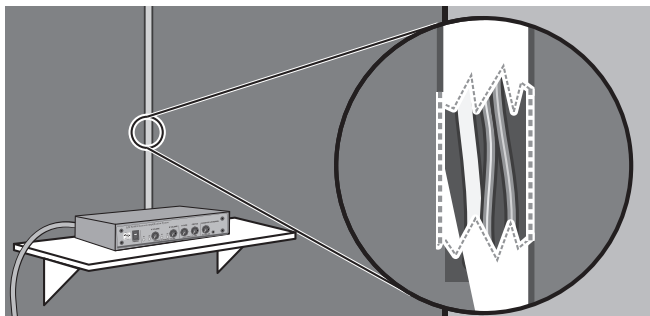

1. ISR SENSOR/RECEIVER INSTALLATION

Once you find a suitable location for the ISR, follow these instructions to mount it. There are different instructions for mounting depending on if the ISR will be mounted to a suspended ceiling grid or secured to a wall / solid vertical surface.

1a. SUSPENDED CEILING MOUNT

1. Attach the bracket to the ceiling tile grid (t-bar).
 - a. Slide the tabs onto the outsides of the t-bar, starting with one corner.
 - b. Attach the second tab around the other side of the t-bar.
 - c. Repeat with the other side of the bracket so it is connected at all four points.
2. Slide the ISR onto the bracket until it "clicks" into place.
 - a. Guide the mounting rails onto the bracket, oriented as pictured.
 - b. Once secure, the ISR locks into place.
 - c. To remove the ISR, press the release bar down and slide the ISR off the bracket.
3. Uncoil the Cat5e sensor cable. Connect one end of the cable to the ISR. Secure wire overhead and route it back to the system.
4. Connect the other end of the Cat5e sensor cable into the SENSOR INPUT jack on the amplifier.

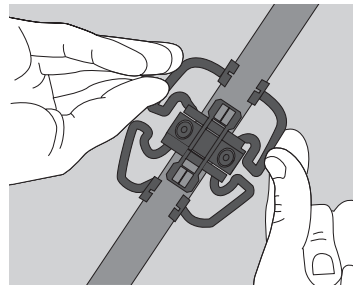

clip connects to t-bar on ceiling

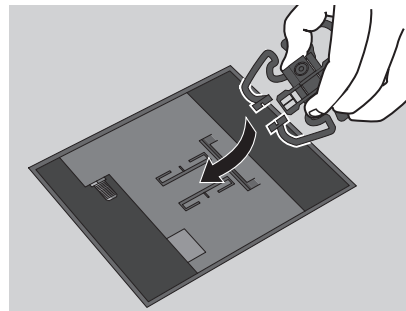
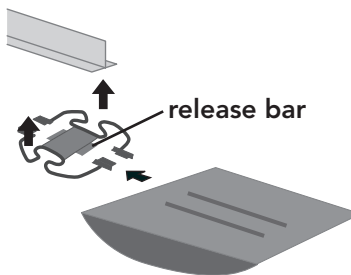

1. ISR SENSOR/RECEIVER INSTALLATION cont'd

1b. WALL/SOLID CEILING MOUNT

1. Screw the bracket to a place high on the wall or in the middle of the solid ceiling. Mount the bracket horizontally.
2. Uncoil the Cat5e sensor cable. Connect one end of the cable to the ISR. Route the wire back to the amplifier, securing it along with way using surface raceway where possible.
3. Slide the ISR onto the bracket until it "clicks" into place.
 - a. Guide the mounting rails onto the bracket, oriented as pictured.
 - b. Once secure, the ISR locks into place. (To remove the ISR, slide a ruler or screwdriver behind the ISR to press the release bar down and slide the ISR off the bracket.)
4. Connect the other end of the Cat5e sensor cable into the SENSOR INPUT jack on the back of the amplifier.

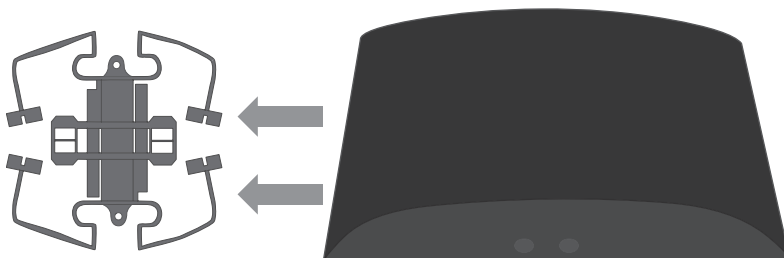

2. ISR CONNECTION TO AMPLIFIER

1. Ensure the power is still switched off.
2. Check the connection from the ISR to the amplifier. Ensure the sensor cable is securely attached and locked into place.

855/885 Amplifier

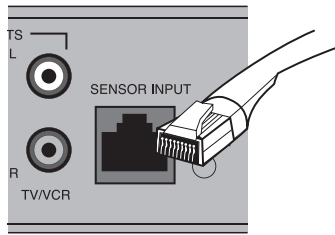

ISR Sensor/Receiver

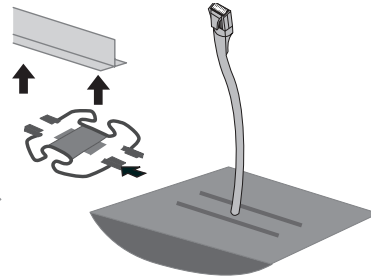

7. Troubleshooting

6. Installing Optional Equipment

5. Set Up & Integration

4. Speaker Location & Installation

3. iR Sensor Location & Installation

2. Installation Planning

1. Overview

3. CONNECTING THE POWER SUPPLY

1. Ensure the power button is in the off position.
2. Connect the DC end of the power supply to the black power jack labeled DC POWER.
3. Connect the black AC power cable from the power supply to a wall outlet.

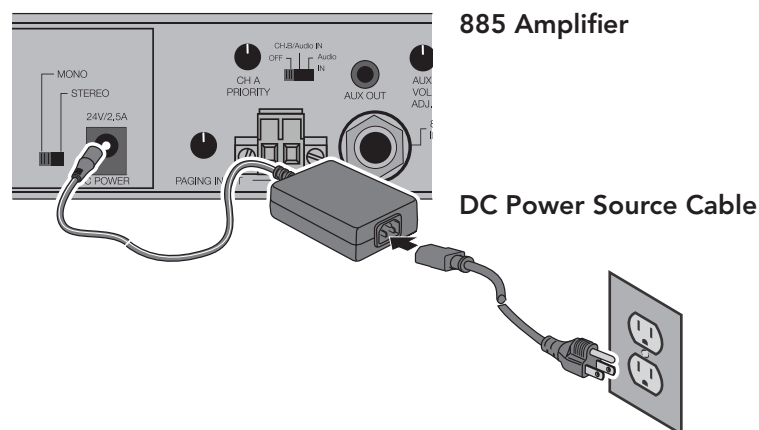
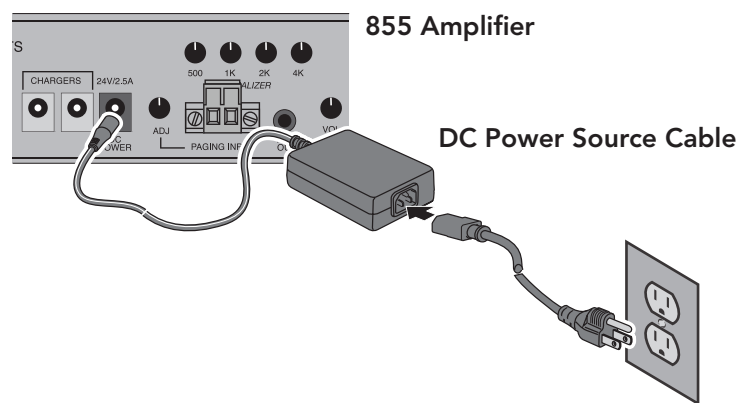

SECTION 4:

SPEAKER LOCATION & INSTALLATION

Tools and equipment that may be needed to install the speakers outlined in this manual:

- Straight edge
- Utility knife or drywall saw
- Screwdriver, standard & phillips
- Screwdriver, small jewelers type ,1/8" wide tip
- Drill driver and bits/drills
- Marker or pencil
- Wire cutters
- Wire strippers
- Wire ties

Locate the specific speaker(s) that were ordered with the system and then follow the installation instructions pertinent to that model of speaker outlined in this section of the manual.

TCQ MULTIMEDIA CEILING SPEAKER INSTALLATION INTRUCTIONS

System Components and Unpacking

- (1) Ceiling grid T-bar (US & Canada use)
- (1) 50 ft (15m) plenum rated speaker wire (If ordered)
- (1) 20ft (6m) coil safety wire
- (4) Self drilling screws (outside U.S. and Canada)
- (1) Mounted ISR sensor
- (1) ISR blank plate (to be installed if ISR needs to be located remotely)
- (1) Bundle of plenum-rated speaker wire (if ordered)

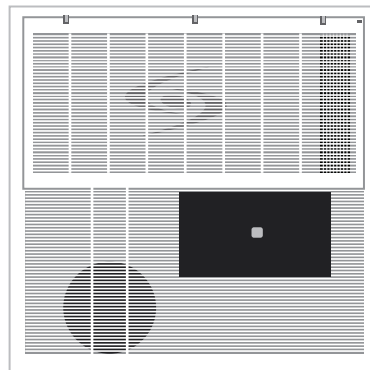

7. Troubleshooting

6. Installing Optional Equipment

5. Set Up & Integration

4. Speaker Location & Installation

3. iR Sensor Location & Installation

2. Installation Planning

1. Overview

TCQ SPEAKER INSTALLATION INTRUCTIONS CONT'D

7. Troubleshooting

6. Installing Optional Equipment

5. Set Up & Integration

4. Speaker Location & Installation

3. iR Sensor Location & Installation

2. Installation Planning

1. Overview

1. SELECTING SPEAKER MOUNTING LOCATIONS

1. One TCQ speaker will distribute sound throughout a classroom of up to 1200 square feet (112 sq m). The location of the speaker is important to ensure even sound distribution. Ceiling height should be 9 - 12 ft (2.75m - 3.75m) in height.
 - a. Identify the center of the of the classroom for optimum location (see figure 1).
 - b. Select a ceiling tile that is free from fixtures (lighting, HVAC, etc.) within a 6ft (1.8m) radius of this center point.
 - c. Remove the selected ceiling tile for speaker installation.

NOTE: Do not install where the integrated sensor/receiver (ISR) is in the reflected light of a hanging light fixture. If necessary to avoid signal dropout, the ISR can be removed from the TCQ and placed elsewhere on the ceiling or classroom wall.

2. TCQ SPEAKER INSTALLATION (U.S. & CANADA ONLY) For 2' x 2' or 2' x 4' Ceiling Grid

The dimensions of the TCQ are 2' x 2'. It is designed to lie onto any standard suspended ceiling tile grid.

1. If the ceiling tile that was removed is 2' x 4', it needs to be cut in half to accommodate the TCQ. If the ceiling tile that was removed is 2' x 2', no cutting of the tile is necessary, skip to Securing the TCQ Speaker.

Figure 1: Identify the center of the room

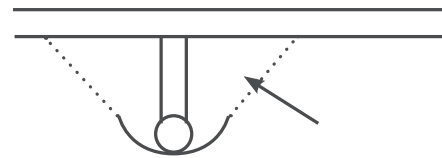
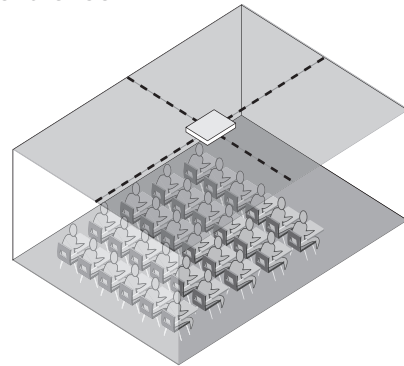
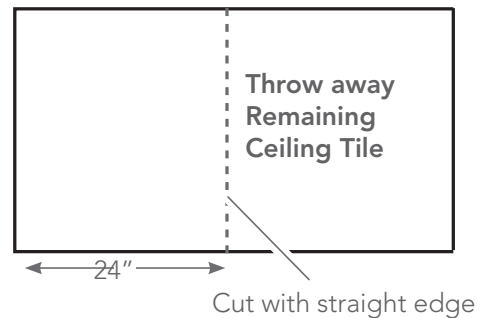

Figure 2: Cut the 2' x 4' Tile in Half



TCQ SPEAKER INSTALLATION INTRUCTIONS CONT'D

2. Set the ceiling tile on a flat work surface with the patterned side facing down.
3. Using a straight edge, cut the 2' x 4' ceiling tile in half (see figure 2) leaving two 2' x 2' sections.
4. Locate the 2' ceiling grid t-bar attachment. Locate the attachment slots in the existing ceiling grid and snap the new t-bar into place to create two 2' x 2' openings (see figure 3).

Figure 3: Create Two 2' x 2' Openings

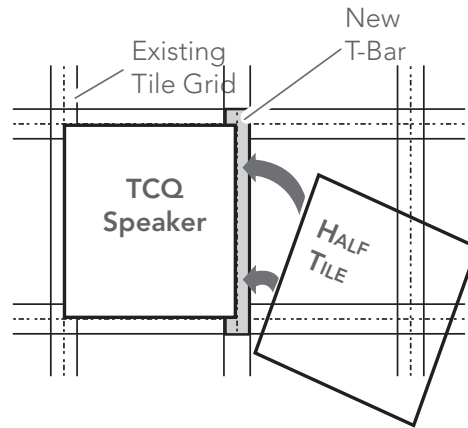

2a. SECURING THE TCQ SPEAKER (U.S. & CANADA ONLY)

To comply with Building Codes, the TCQ MUST be secured to the building structure with 2 safety wires.

Installing Safety Wire:

1. Locate the 20ft length of safety wire. The safety wire needs to be permanently attached to the solid building structure with metal clips, tie point studs, concrete anchors or eye screws designed for the specific structure material. The specific anchors will need to be provided by the installer.
2. Cut the safety wire in half, leaving two 10ft pieces.
3. Install the appropriate anchor into the building structure. (figure 4)
4. Loop one end of the safety wire through the anchor (or eye screw), then twist it around itself at least five times. Repeat for the second anchor tie point. (figure 4)

Figure 4: Looping the Safety Wire Through the Tab

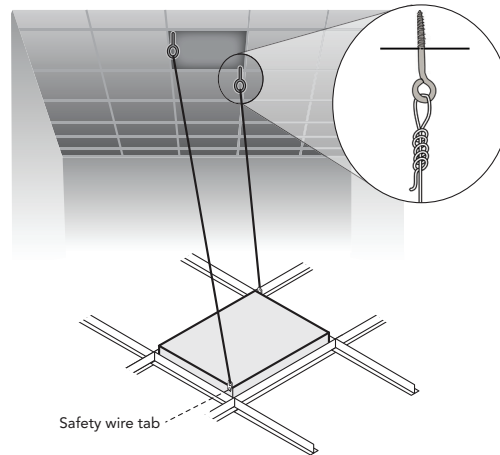

7. Troubleshooting

6. Installing Optional Equipment

5. Set Up & Integration

4. Speaker Location & Installation

3. iR Sensor Location & Installation

2. Installation Planning

1. Overview

TCQ SPEAKER INSTALLATION INTRUCTIONS CONT'D

7. Troubleshooting

6. Installing Optional Equipment

5. Set Up & Integration

4. Speaker Location & Installation

3. iR Sensor Location & Installation

2. Installation Planning

1. Overview

5. Lift the TCQ up and lay it into the desired grid location. (see figure 5)

Caution: Make sure the TCQ is stable on the grid rails with side brackets capturing the t-bar grid. If not stable, there could be a danger of it falling until safety wires are attached.

6. Use a small screwdriver to bend up one of the safety wire tabs on the TCQ (located in opposite corners) and loop the other end of the safety wire through the tab. Pull the wire through until it is taut and twist it around itself at least five times to secure the TCQ. (see figure 4) Cut off any excess wire as needed.
7. Repeat with securing the second safety wire to the other tab.
8. Plug in the 50ft 18 awg, 2 conductor plenum-rated speaker wire (or supply if not ordered) into the green euro-style connector on the back of the enclosure. If the ISR sensor is installed, run the attached 50ft Cat5e ISR sensor cable and speaker wire over to the amplifier using proper wiring methods per local codes.
9. To continue with installation, go to Page 36- Connecting Wire to Amplifier.

Figure 5: Set speaker into ceiling

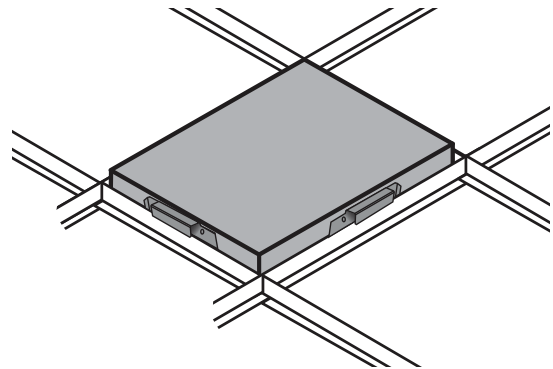

TCQ SPEAKER INSTALLATION (OUTSIDE U.S. & CANADA ONLY) *For 600mm x 600mm Ceiling Grid*

3a. SECURING THE TCQ SPEAKER (OUTSIDE U.S. & CANADA ONLY)

To comply with Building Codes, the TCQ MUST be secured to the building structure with 2 safety wires.

The TCQ has spacer brackets mounted on each of the four sides. With these brackets installed, the TCQ will fit a standard 2' x 2' suspended ceiling grid. With the brackets removed, it will fit a 600mm x 600mm ceiling grid.

Remove the spacer brackets from each of the four sides of the TCQ.

Note: If your ceiling grid is any other dimension than mentioned above, contact your local Lightspeed reseller.

INSTALLING SAFETY WIRE:

1. Locate the 6m length of safety wire. The safety wire needs to be permanently attached to the solid building structure with metal clips, tie point studs, concrete anchors or eye screws designed for the specific structure material. The specific anchors will need to be provided by the installer.
2. Cut the safety wire in half, leaving two 3m pieces.
3. Install the appropriate anchor into the building structure. (see figure 6)
4. Loop one end of the safety wire through the anchor tie-point, then twist it around itself at least five times. Repeat for second anchor tie point. (see figure 6)
5. Lift the TCQ up and lay it into the desired grid location. (see figure 7)

Caution: Make sure the TCQ is stable on the grid rails. If not stable, there could be a danger of it falling until safety wires are attached.

Figure 6: Looping the Safety Wire Through the Tab

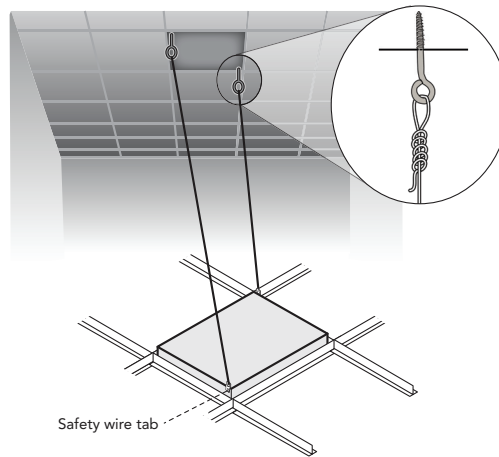

TCQ SPEAKER INSTALLATION (OUTSIDE U.S. & CANADA ONLY) cont'd

1. Pull one of the tabs up on the TCQ (located in opposite corners) and loop the other end of the safety wire through the tab. Pull the wire through until it is taut and twist it around itself at least five times to secure the TCQ. Cut off any excess wire as needed. (see figure 5)
2. Repeat with securing the second safety wire to the other tab.
3. Locate the four (4) self-tapping sheet metal screws.
4. Utilizing existing holes 1/3 to 1/2 way in from the side on the vertical section of the grid T-bar, drill one screw per side into the TCQ speaker taking care not to bend or distort the grid rails (see figure 6).
5. Plug in the 15m 18 awg, 2 conductor plenum-rated speaker wire (or supply if not ordered) into the green euro-style connector on the back of the enclosure. If the ISR sensor is installed, run the attached 15m ISR sensor Cat5e cable and speaker wire over to the amplifier using proper wiring methods per local codes.

Figure 7: Secure with Self-tapping screws into the TCQ

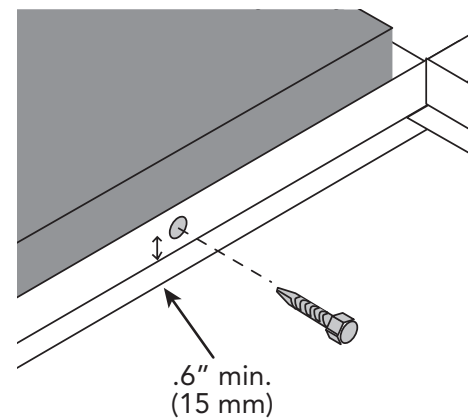

Note: Drilling these screws into the TCQ chassis will not cause harm to the product.

TCQ SPEAKER INSTALLATION cont'd

3. OPTIONAL CONDUIT CONNECTION

1. Locate and uncoil the Cat5e sensor cable coming out of the back of the TCQ speaker.
2. Thread this cable through a standard single-gang j-box with ears (not provided).
3. Locate the 15m 18 awg, 2 conductor plenum-rated speaker wire (or supply, if not ordered) and the green euro-style connector located on the back of the amplifier.
 - a. Connect one end of the speaker wire to the euro-block connector.
 - b. Insert the positive conductor (RED or WHITE in color) into the right side of the connector and use a small flat head screwdriver to tighten
 - c. Insert the negative conductor (BLACK) into the left side of the connector and tighten, as above.
 - d. Thread terminated end of the speaker wire through the j-box and connect to the green euro-style connector on the back of the TCQ.
4. Attach j-box to back can of speaker utilizing the 4 existing screw holes. Four standard #6 x .5" long sheet metal screws (or reasonable equivalent) should be used.
5. Thread both the Cat5e cable and plenum speaker wire through conduit.
 - a. The conduit can then be routed to the appropriate j-box or outlet for installation.
 - b. The conduit can then be attached to j-boxes using appropriate connectors.
 - c. Ensure there is a 12-inch service loop in terminating the outlet box.
6. To continue with installation, go to Page 36 - Connecting Wire to Amplifier

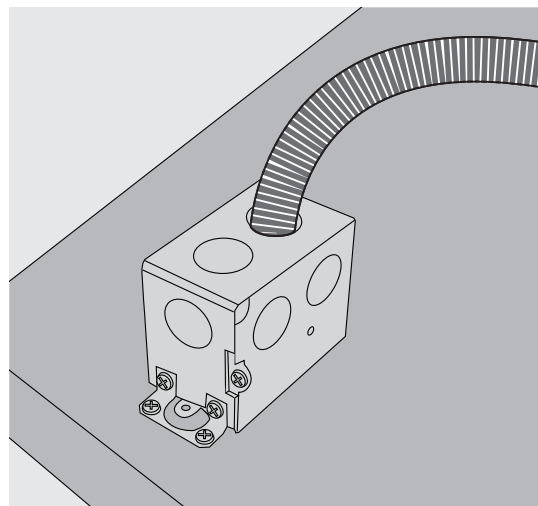
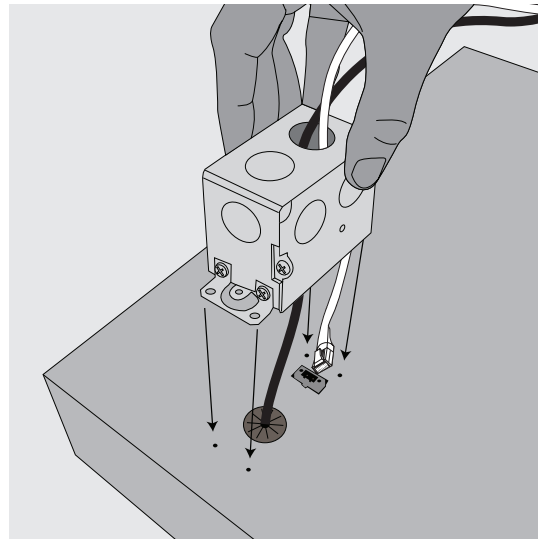
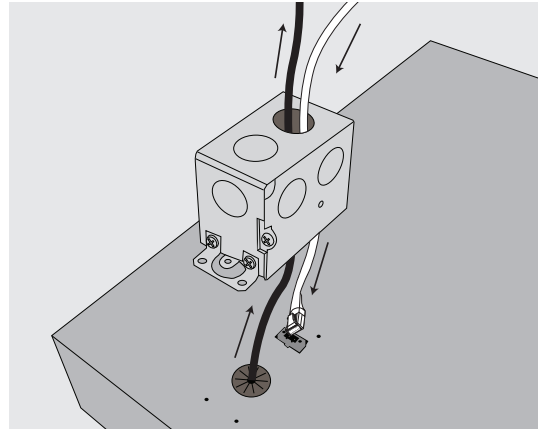

7. Troubleshooting

6. Installing Optional Equipment

5. Set Up & Integration

4. Speaker Location & Installation

3. iR Sensor Location & Installation

2. Installation Planning

1. Overview

DRQ CEILING SPEAKER INSTALLATION INSTRUCTIONS

Tools and Equipment

- Small flathead screwdriver
- Philips screwdriver
- Marker or pencil
- Drywall saw

Speaker Components

- (4) DRQ speakers
- (4) Tile bridges
- (2) 30 ft bundles of plenum-rated speaker wire (if ordered) marked with a white band
- (2) 50 ft bundles of plenum-rated speaker wire (if ordered) marked with a blue band

1. SELECTING SPEAKER MOUNTING LOCATIONS

A standard system includes 4 ceiling speakers for rooms up to 1600 sq ft (148sqm) with a ceiling height of 9-12 feet (2.75m - 3.75m). The location of the speakers is critical for even sound distribution.

1. Quarter the classroom into four equal quadrants. (see figure 1)
2. Select a ceiling tile that is centered in each quadrant.
3. Remove the selected ceiling tiles for speaker installation.

2. INSTALLING THE SPEAKERS INTO THE CEILING TILE

Before beginning the speaker tile work, choose a flat work surface

1. Lay the tile bridge across the backside of the ceiling tile as shown in Figure 2. Using a marker or pencil, trace out the cutout circle as a template.
2. Using a drywall saw or jigsaw, cut out a circular hole as neatly as possible. NOTE: to ensure the hole is large enough, cut slightly outside the mark.
3. Remove the speaker grille by turning and pushing one of the arms upward (see figure 3). Or use the grille removal tool, insert one end into one of the holes near the edge and pull the grille off.

Figure 1: Speaker Placement

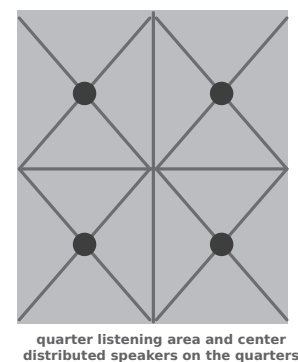
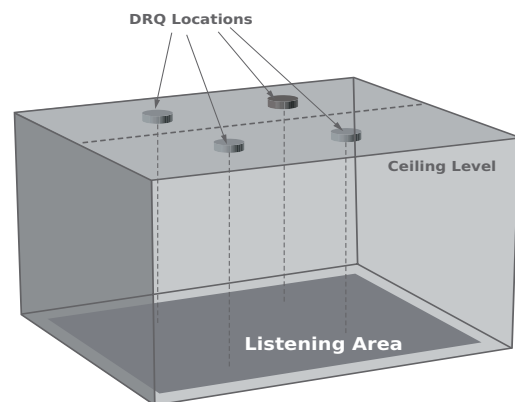
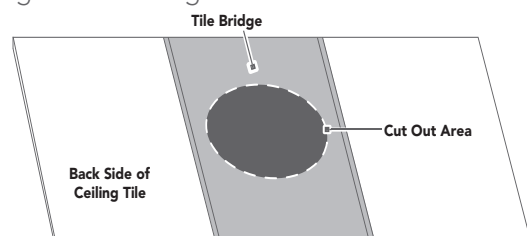

Figure 2: Cutting the Tile



DRQ CEILING SPEAKER INSTALLATION INSTRUCTIONS

cont'd

4. Turn the tile on its side and insert the speaker into the front side of the tile. Place the tile bridge around the back-side of the speaker, oriented horizontally across the tile (as shown in Figure 2).
5. Use a screwdriver (or screwgun) to tighten the four mounting screws (see figure 4). NOTE: the first quarter turn pulls the mounting tabs away from the speaker enclosure, then it begins tightening.
6. Repeat steps 2-5 for each speaker and tile.

3. CONNECTING AND ROUTING SPEAKER WIRE

Prep two conductor 18 awg plenum rated speaker wire ends for insertion into the speaker connectors. NOTE: it is advised to prep and connect each speaker at ground level.

1. Distribute the appropriate lengths of wire to each speaker (see Figure 5). There should be (2) 30 ft lengths of wire between two pairs of speakers. There should be (2) 50 ft lengths of wire for home runs back to the amplifier.
2. At Speaker #1, remove the euro-block connector on the back of the speaker.
3. Connect one length of speaker wire to the -+ terminals marked as INPUT on the speaker, paying attention to polarity (BLACK is "-", RED is "+"). Tighten the screw on bottom of the connector with small screwdriver to secure. This length of wire will be routed back to the amplifier.
4. Connect a second length of speaker wire to the second set of -+ terminals marked as OUTPUT on the speaker, paying attention to polarity. Tighten the screws to secure. This wire will be routed to Speaker #2.
5. Route the wire to Speaker #2. Secure and conceal wire as needed.
6. At Speaker #2, remove the euro-block connector.

Figure 3: Remove the Grille

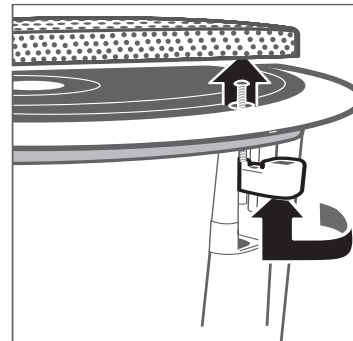
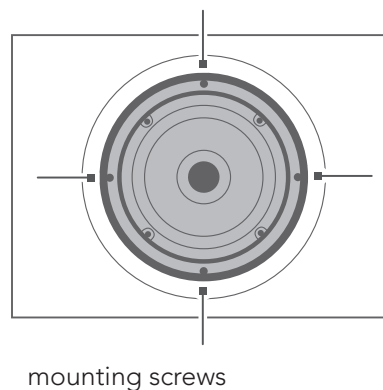

Figure 4: Mount Speaker



7. Troubleshooting

6. Installing Optional Equipment

5. Set Up & Integration

4. Speaker Location & Installation

3. iR Sensor Location & Installation

2. Installation Planning

1. Overview

DRQ CEILING SPEAKER INSTALLATION INSTRUCTIONS cont'd

7. Connect the wire to the input set of -+ connectors , paying attention to polarity and tighten the screws on top to secure.
8. Repeat 2 through 7 to connect Speakers #3 and #4. Note that only two speakers can be wired together per amplifier output (minimum 4 ohm load).
9. Route the wires from Speaker #1 and #3 back to the amplifier as indicated in figure 3. Note that there must be a service loop of 8 to 10 ft at the speakers and the speaker wire cut to length at the amplifier.
10. Secure all speaker wire above the ceiling tiles with wire ties or wiring clips and use surface mounted raceway for any exposed wiring coming down the wall to the amplifier. This is required by code in most, if not all jurisdictions.
11. To continue with installation, go to Page 36- Connecting Wire to Amplifier.

Figure 5: Wiring Diagram

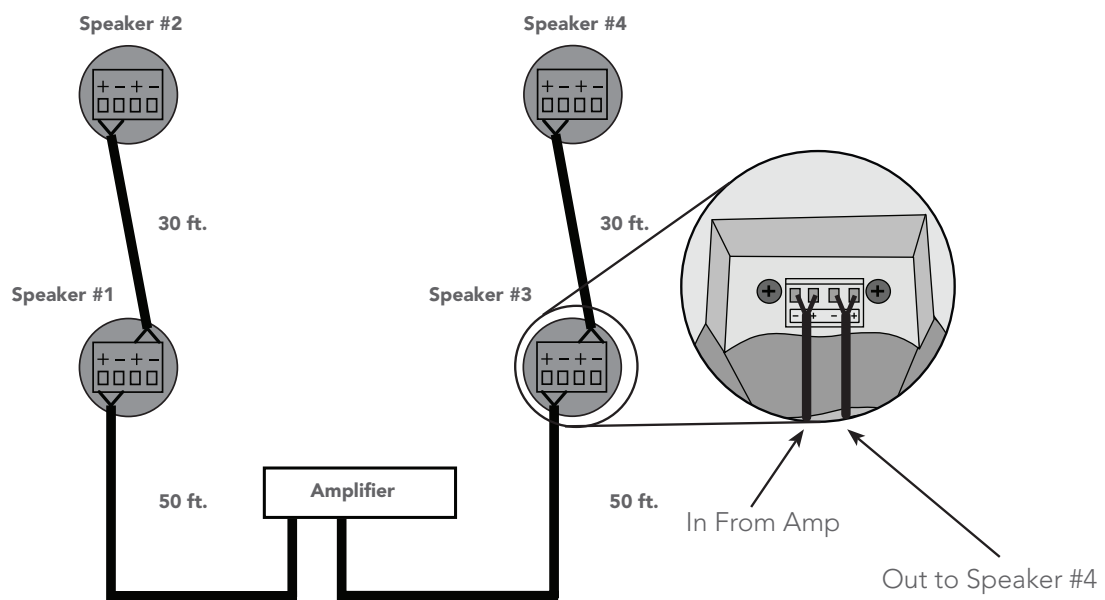

WMQ WALL SPEAKER INSTALLATION INSTRUCTIONS

Tools and Equipment

- Small flathead screwdriver
- Drill with 3/16" (.1875mm) drill bit
- Phillips head screwdriver
- Marker or pencil

Speaker Components

- (4) WMQ speakers
- (4) Wall mount brackets
- (4) Sets of mounting hardware (screws and drywall anchors)
- (2) 50 ft bundles of plenum-rated speaker wire (if ordered) marked with a blue band
- (2) 75 ft bundles of plenum-rated speaker wire (if ordered) marked with a red band

1. SELECTING SPEAKER MOUNTING LOCATIONS

A standard system includes 4 wall speakers for rooms up to 1600 sq ft (148 sq m) with a ceiling height of 8-12 feet (2.4 - 3.75m). The location of the speakers is critical for even sound distribution.

1. Refer to Figure 1 for speaker positioning recommendations.
2. Ideally speakers should be staggered on all four walls (Optimum).
3. When all four walls are not available, refer to the other diagram for alternative positioning.
4. Speakers should not be positioned directly opposite of one another.
5. When speakers are mounted, they should be tilted down toward the specific listening area indicated on the diagrams.
6. Depending on ceiling height, speakers should be placed 7.5 ft to 12 ft high (2.35 - 3.75m).

WMQ Speaker

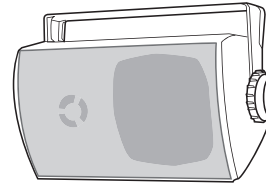
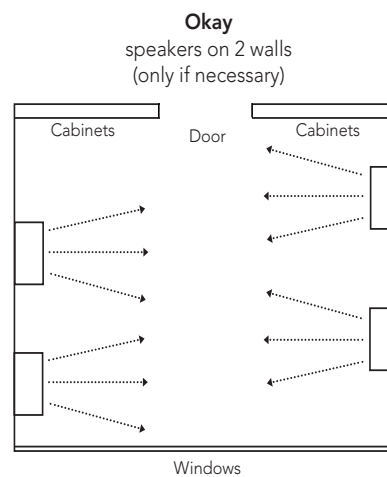
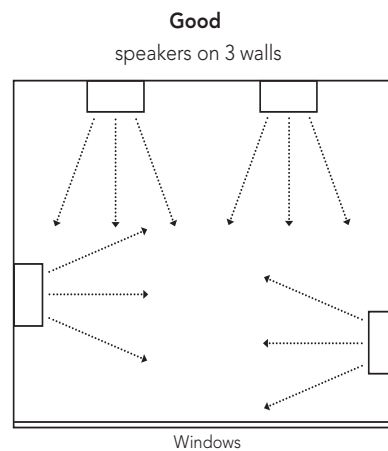
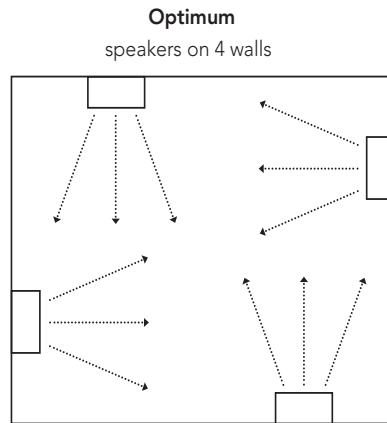

Figure 1: Speaker Placement



WMQ WALL SPEAKER INSTALLATION INSTRUCTIONS cont'd

7. Troubleshooting

6. Installing Optional Equipment

5. Set Up & Integration

4. Speaker Location & Installation

3. iR Sensor Location & Installation

2. Installation Planning

1. Overview

7. If the walls are drywall, drill pilot holes with a 3/16" (.1875mm) drill bit, then screw in the supplied drywall anchors.
8. While holding the bracket against the wall, drill the mounting screws into the drywall anchors (or directly into a stud).
9. Place the WMQ speaker between the two bracket arms, aligning the mounting holes.
10. Insert the large plastic mounting screw into the two sides of the speaker and tighten with your fingers.
11. Direct the speaker at the appropriate angle to cover the desired area of the classroom (see Figure 1).

Figure 2: Mounting the Speaker

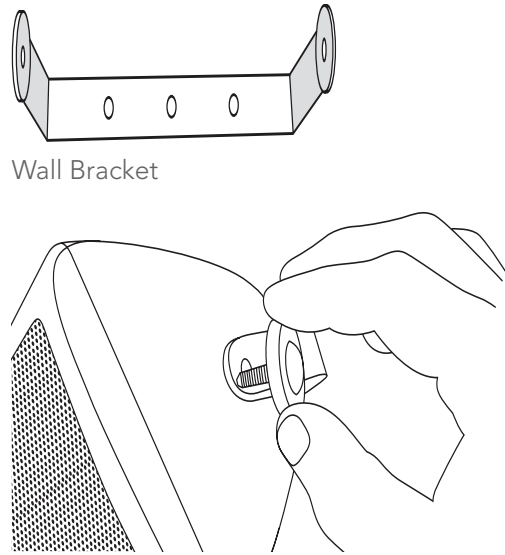
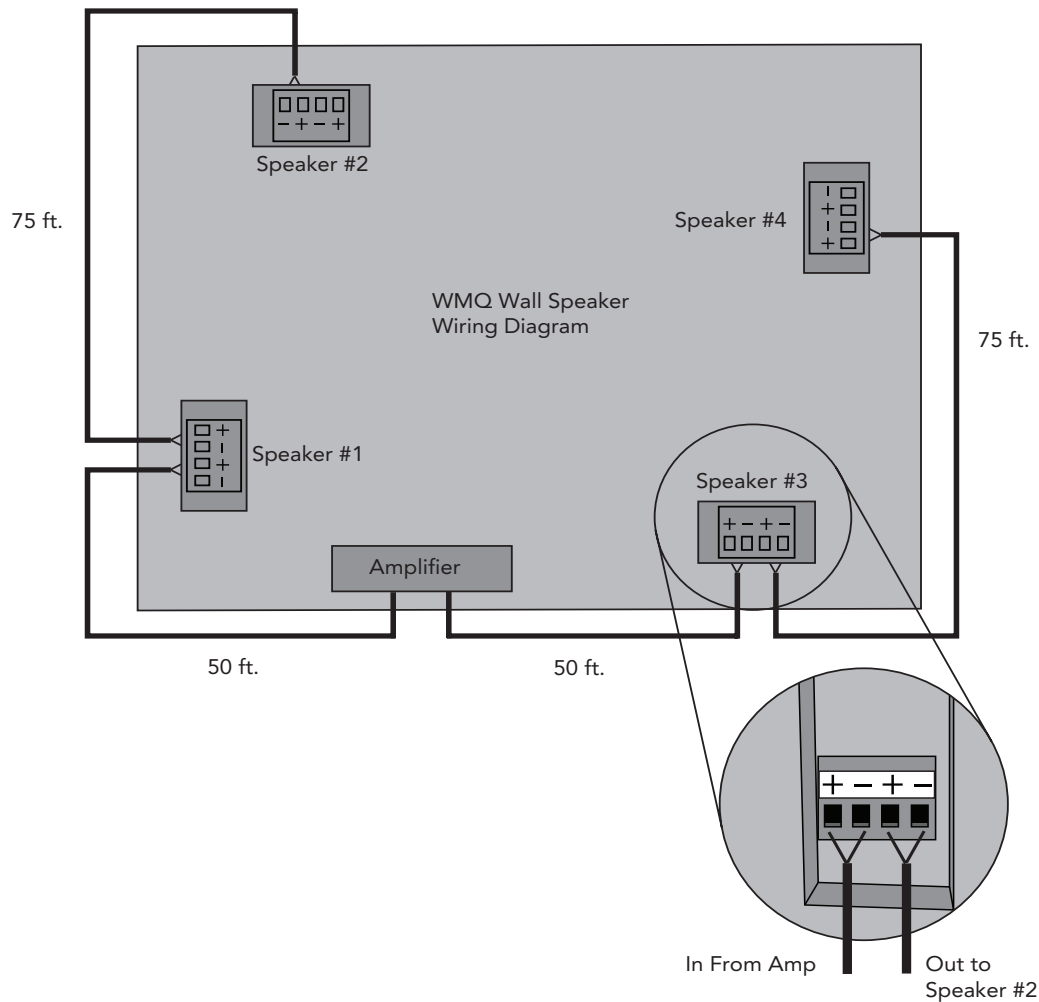

Figure 3: Wiring Diagram



WMQ WALL SPEAKER INSTALLATION INSTRUCTIONS cont'd

2. CONNECTING AND ROUTING SPEAKER WIRE

Locate the plenum rated wire included with the speaker components (If ordered).

1. Distribute the appropriate lengths of wire to each speaker (see Figure 3). There should be (2) 50 ft lengths of wire between two pairs of speakers. There should be (2) 75 ft lengths of wire for home runs back to the amplifier.
2. At Speaker #1, remove the euro-block connector on the back of the speaker.
3. Connect one 75 ft length of speaker wire to the +- connector, paying attention to polarity (BLACK is "-", RED is "+"). Tighten the screw on top of the connector with small screwdriver to secure. This length of wire will be routed back to the amplifier. Note that there must be a service loop of 8 to 10 ft at the speaker and the speaker wire cut to length at the amplifier.
4. Connect a 50 ft length of speaker wire to the second set of +- jacks on the connector (see figure 3) paying attention to polarity. Tighten the screws to secure and plug the connector back into the speaker. This wire will be routed to Speaker #2.
5. Route the wire to Speaker #2. Secure and conceal wire as needed.
6. At Speaker #2, remove the euro-block connector.
7. Connect the wires to the +- connectors on the input, paying attention to polarity and tighten the screws on top to secure and plug back into the speaker.
8. Repeat 2 through 7 to connect Speakers #3 and #4.
9. A 75 ft length of wire will be routed back to the amplifier. Note that there must be a service loop of 8 to 10 ft at the speaker and the speaker wire cut to length at the amplifier.
10. To continue with installation, go to Page 36 - Connecting Wire to Amplifier.

7. Troubleshooting

6. Installing Optional Equipment

5. Set Up & Integration

4. Speaker Location & Installation

3. iR Sensor Location & Installation

2. Installation Planning

1. Overview

4JCS CEILING SPEAKER INSTALLATION INSTRUCTIONS (Plenum Rated)

Tools and Equipment

- Straight edge
- Marker
- Scissors (template)
- Utility knife
- Screwdriver
- Plenum rated pass-through or conduit hardware (not included)

Speaker Components

- (4) Speaker/baffle assembly
- (4) Tile bridge
- (4) Speaker enclosure
- (16) Mounting screws
- (8) Wire nuts
- (2) 30 ft bundles of plenum-rated speaker wire (if ordered) marked with a white band
- (2) 50 ft bundles of plenum-rated speaker wire (if ordered) marked with a blue band

Figure 1: Exploded View

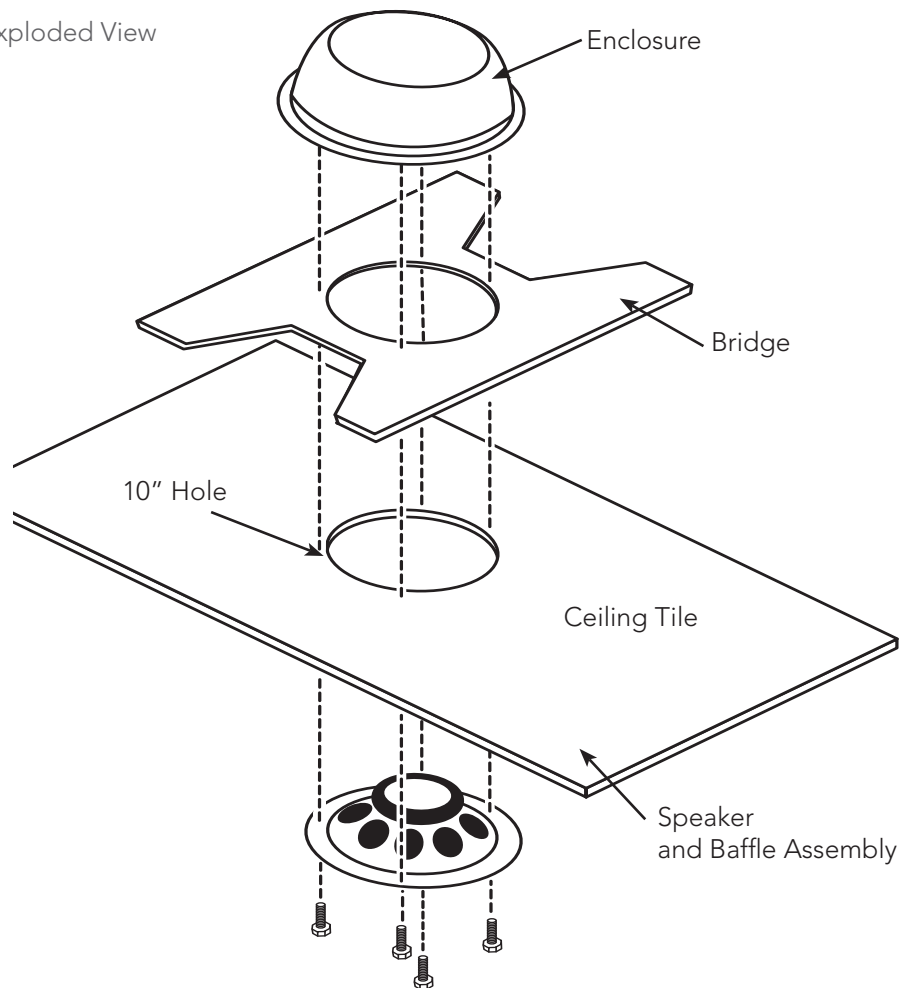

4JCS CEILING SPEAKER INSTALLATION INSTRUCTIONS (Plenum Rated) cont'd

1. SELECTING SPEAKER MOUNTING LOCATIONS

A standard system includes 4 ceiling speakers for rooms up to 1600 sq ft (148sqm) with a ceiling height of 9-12 feet (2.75m - 3.75m). The location of the speakers is critical for even sound distribution.

1. Quarter the classroom into four equal quadrants. (see figure 1)
2. Select a ceiling tile that is centered in each quadrant.
3. Remove the selected ceiling tiles for speaker installation.

2. INSTALLING THE SPEAKERS INTO THE CEILING TILE

Before beginning the speaker tile work, choose a flat work surface.

1. Using the straight edge, determine the center of each ceiling tile by drawing a straight line from corner to corner on the back of the tile.
2. Using the center point, mark a 10" circle on the back of the tile. NOTE: A semi-circle template is included (see Figure 3a, 3b).

Figure 2: Speaker Placement

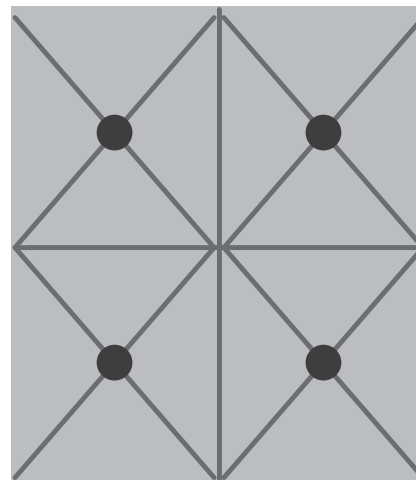
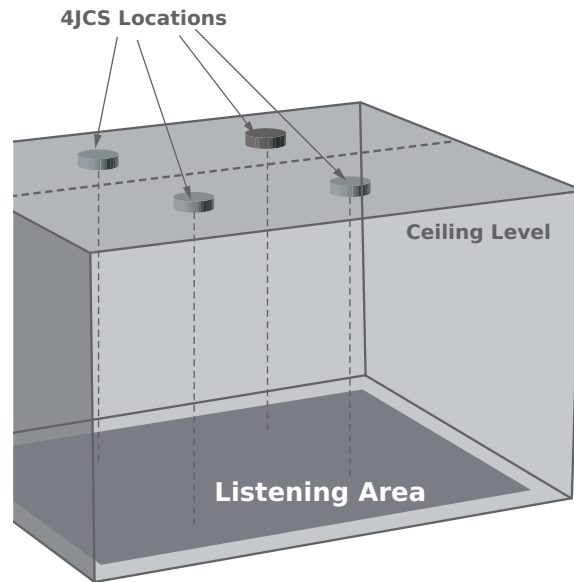

quarter listening area and center distributed speakers on the quarters

7. Troubleshooting

6. Installing Optional Equipment

5. Set Up & Integration

4. Speaker Location & Installation

3. iR Sensor Location & Installation

2. Installation Planning

1. Overview

4JCS CEILING SPEAKER INSTALLATION INSTRUCTIONS (Plenum Rated) cont'd

3. Using a utility knife or jigsaw, cut out the circular hole in the center of the tile as neatly as possible. The speaker baffle will cover up some minor rough edges. NOTE: To ensure the hole is large enough, cut slightly outside template lines (see figure 3c).
4. Turn the tile on its side and insert the speaker into the front side of the tile and place the tile bridge horizontally across the back of the tile. Holding the speaker and tile bridge in place, start all four of the mounting screws. Use a screwdriver to tighten the four mounting screws to secure the speaker, tile bridge and tile together (see figure 3d).
5. Repeat steps 1 through 4 for each of the remaining speakers and tiles.

Figure 3: Installing Speakers into the Ceiling Tile

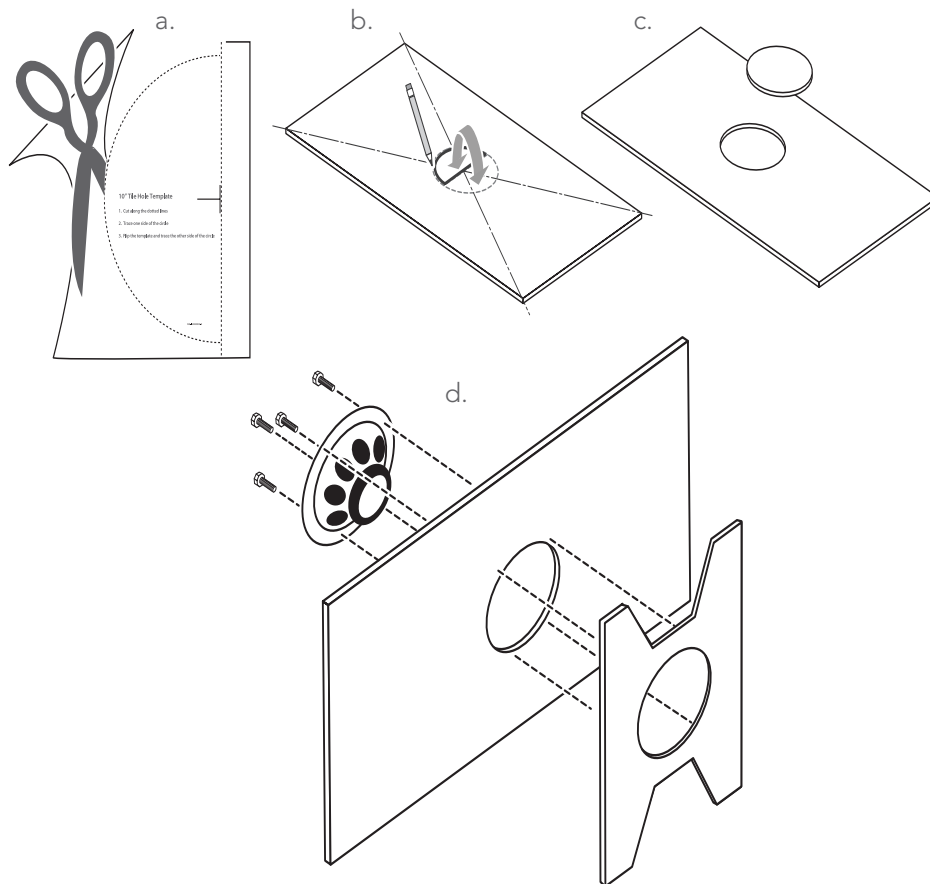

4JCS CEILING SPEAKER INSTALLATION INSTRUCTIONS (Plenum Rated) cont'd

3. CONNECTING AND ROUTING SPEAKER WIRE

Prep two conductor 18 awg plenum rated speaker wire ends for insertion into the speaker connectors. NOTE: it is advised to prep and connect each speaker at ground level.

1. Distribute the appropriate lengths of wire to each speaker (see Figure 5). There should be (2) 30 ft lengths of wire between two pairs of speakers. There should be (2) 50 ft lengths of wire for home runs back to the amplifier.
2. Start with speaker #1 (see Figure 4).
3. Remove a conduit knockout in the speaker enclosure and install a plenum-rated low voltage pass-through or conduit hardware in the enclosure (not included).
4. Route the speaker wire through the conduit hardware and attach to the speaker terminals by twisting the speaker wire and speaker pigtails together, securing with the included wire nuts. Be sure to maintain proper polarity (see figure 4).

Figure 4: Wiring Diagram

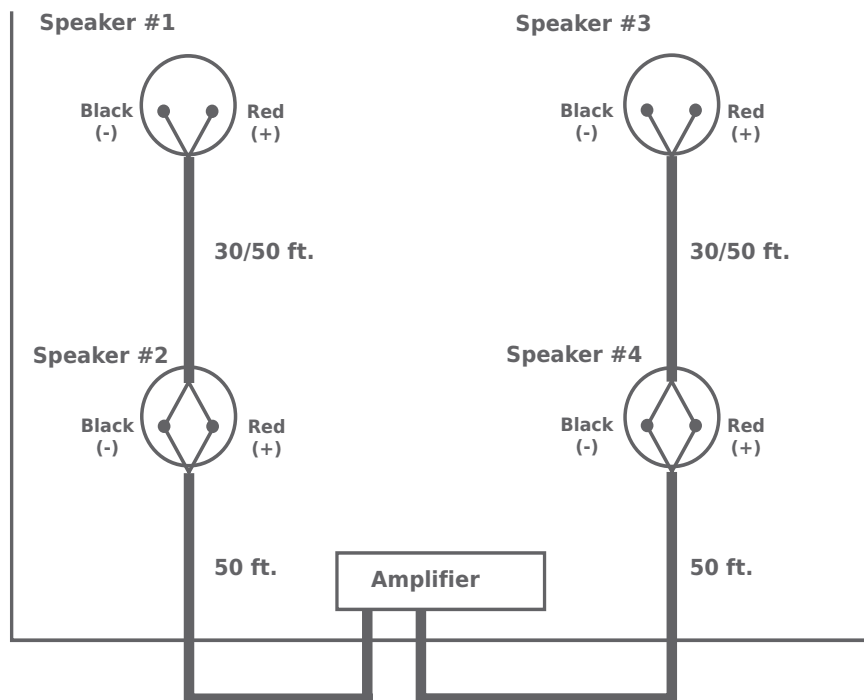

4JCS CEILING SPEAKER INSTALLATION INSTRUCTIONS (Plenum Rated) cont'd

5. Install the speaker enclosure on the tile bridge securing it in place by turning the enclosure clockwise (see figure 5).
6. Install speaker #1 with tile into the ceiling grid and route cabling (following local building codes) to speaker #2.

NOTE: Building codes vary for state to state and county to county. It may be required that the speaker itself be secured to a support wire.

7. Remove a conduit knockout in speaker #2's enclosure and install a plenum-rated low voltage pass-through or conduit hardware to the enclosure (not included).
8. Route speaker #1 wire and speaker #2 wire (50ft if ordered) through the conduit hardware and attach to the speaker terminals by twisting the speaker wire and speaker pigtails together, securing with the included wire nuts. Be sure to maintain proper polarity (see figure 4).
9. Install the speaker enclosure on the tile bridge securing it in place by turning the enclosure clockwise (see figure 5).
10. Install speaker #2 with tile into ceiling grid and route cabling (following local building codes) to the receiver/amplifier.
11. Repeat steps 3 through 10 for speakers #3 and #4.
12. To continue with installation, go to Page 36 - Connecting Wire to Amplifier.

Figure 5: Securing the Enclosure

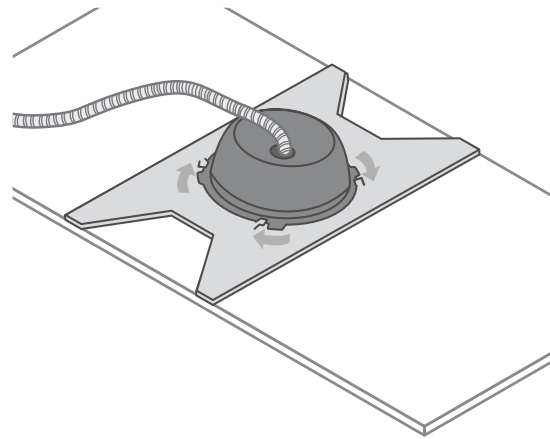

CONNECTING WIRE TO AMPLIFIER

Cat 855 (Figure 5)

1. Unplug the euro-block SPEAKER OUTPUT connector from the amplifier.
2. Insert the two wires into the connector, paying close attention to polarity (+ - - +).
3. Insert the red (+) wire and black (-) wire from speakers #1 and #2 into the left side of the connector (SPEAKER OUTPUT 1). Tighten the screw on top of the connector with small screwdriver to secure.
4. Repeat with the 2nd wire from speakers #3 and #4, paying attention to polarity.
5. Plug the euro-block connector back into the amplifier and secure using the two side screws.

Figure 5: Connecting Speaker Wire to Back of 855 or 885

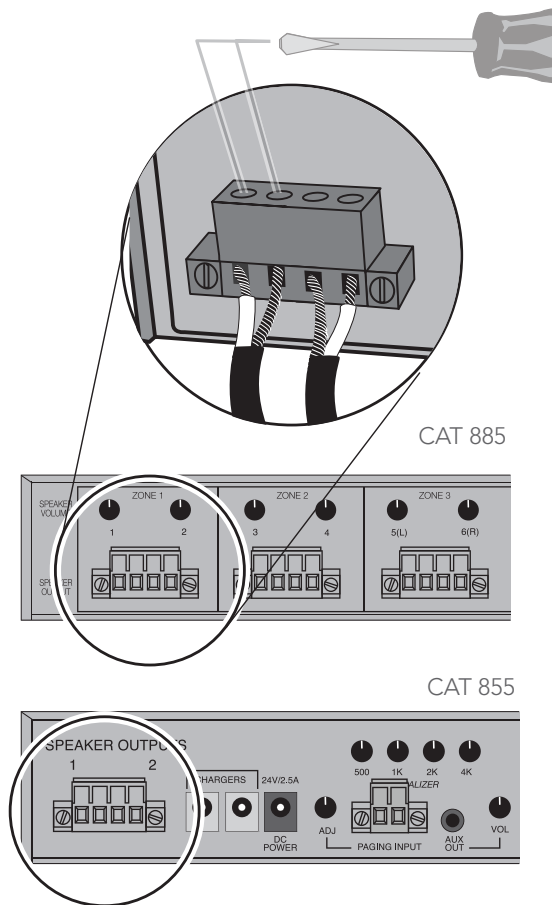

Cat 885 (Figure 5)

1. The corresponding speaker volume is preset in the maximum position. If adjustment is necessary for balancing the room, it can be turned down.
2. As an optional wiring method, each speaker can be connected directly to the amplifier (home runs) so they can be zoned individually.
3. Up to 2 speakers can connect to each output, allowing for a maximum of 12 speakers.
4. Stereo Speaker Output:
 - a. It is recommended that the system be left in mono to ensure all students in the classroom hear the same audio signal.
 - b. If it is desired to amplify multimedia sources in stereo, move the selection switch to the right of the speaker outputs.
 - c. This only impacts outputs 5 and 6, switching them to Left and Right.
 - d. Voice will remain mono, only the devices connected to the audio inputs will be amplified in stereo.
 - e. Any speakers connected to output #5 will produce the Left signal, and those connected to #6 produce the Right signal coming from the multimedia devices.

7. Troubleshooting

6. Installing Optional Equipment

5. Set Up & Integration

4. Speaker Location & Installation

3. iR Sensor Location & Installation

2. Installation Planning

1. Overview

SECTION 5:

SET UP AND INTEGRATION

1. CHARGING THE REDMIKE AND REDMIKE VC

Before use, the Redmike should be charged. It will take 8-9 hours for the Redmike to obtain a full charge. A fully charged Redmike will last for over 7 hours of use. If microphones are used daily, they should be kept in the cradle – microphones can be left in a charging cradle constantly for up to 2 weeks without causing degradation to battery life.

A red light on the charging cradle indicates the Redmike is charging. A green light indicates that charging is complete and a full charge has been reached. A blinking light indicates a charging or sensing error. See Troubleshooting section for more information.

Redmike incorporates alkaline protection into the microphone design. Always use a Lightspeed rechargeable sensing battery. Replacement AA NiMH batteries may only be purchased through Lightspeed Technologies (part # NH2A27). Do not attempt to charge alkaline batteries. They can overheat and expand creating a significant hazard and damaging the microphone (this is not covered by warranty).

1. Plug power cord into the cradle charger and then plug the AC end into an electrical outlet.
2. Ensure that the Redmike is turned off.
3. Place the Redmike into the cradle. The LED on the cradle will glow red indicating charging has started. When the Redmike is fully charged the LED on the cradle charger will change to green.

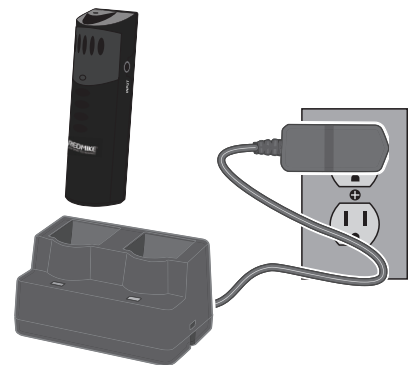
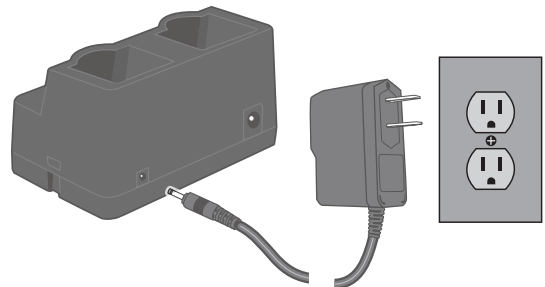

1. CHARGING THE REDMIKE AND REDMIKE VC cont'd

Redmike VC : Charging

Before use, the Redmike VC should be charged. See page 37 and follow the same instructions for the Redmike.

Redmike VC : Initial Set-up

See page 39 and follow the same instructions for the Redmike to setup the Redmike VC.

The teacher can now use the controls on the Redmike VC to adjust the volume level from anywhere in the room. The microphone volume control has 4 steps up and 4 steps down from the mid point (9 levels total). The Redmike VC is preset at mid-point at the factory.



7. Troubleshooting

6. Installing Optional Equipment

5. Set Up & Integration

4. Speaker Location & Installation

3. iR Sensor Location & Installation

2. Installation Planning

1. Overview

2. OPERATING THE REDMIKE

Once the Redmike is charged, follow these steps to set it up for use.

1. Turn the amplifier power on. The blue LED will glow.
2. Remove the Redmike from the charging cradle and turn it on.
3. Slip the Redmike with lanyard around the neck. The mic will be positioned at approximately the top of the collarbone.
4. While speaking in a normal voice, slowly increase the volume of the corresponding channel on the amplifier until your voice is barely audible. Each Redmike has its channel pre-set to either A or B, as indicated on the back of the Mic.

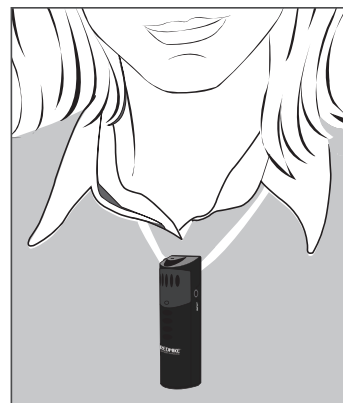

REMEMBER: This equipment supplements the user's voice so they are able to speak in a conversational tone. Having the volume set too high will result in feedback and listener fatigue.

5. Once initial volume level is set, walk around the room and listen for audio dropout and overall audio quality. Fine-tuning the audio is accomplished by making minor adjustments to the equalizer on the back panel of the amplifier.
6. If a second Redmike was purchased, repeat steps 2-4.

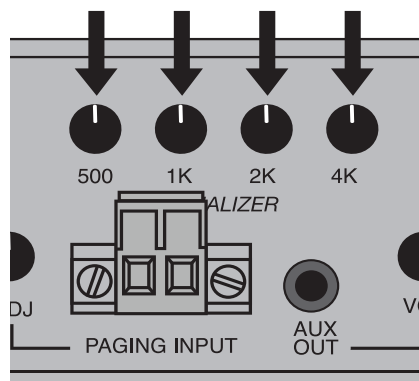

3. CHARGING THE REDMIKE SHARE

1. Ensure that the Redmike Share is turned off.
2. Make sure the cradle charger is plugged into a wall outlet. Connect one end of the charging cable into the jack labeled CHARGER on the bottom of the Redmike Share.
3. Plug the other end into the charging jack on the rear of the cradle charger.
4. The LED on the microphone will glow red to indicate charging.
5. Leave the Redmike Share plugged in overnight (8-10 hours) to obtain a full charge. The LED will blink red when charging is complete.

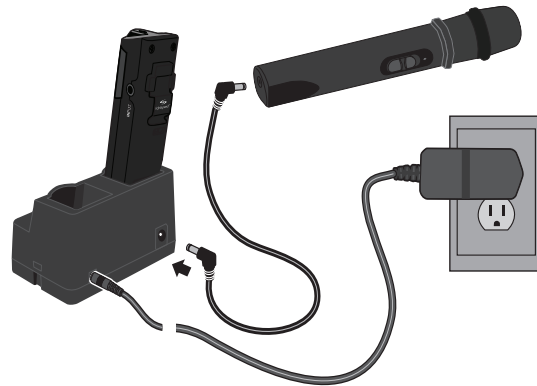

NOTE: The Redmike Share can utilize the charger jacks on the back of the 855.



7. Troubleshooting

6. Installing Optional Equipment

5. Set Up & Integration

4. Speaker Location & Installation

3. iR Sensor Location & Installation

2. Installation Planning

1. Overview

4. OPERATING THE REDMIKE SHARE

1. Ensure the 855 or 885 is on. The LED on the power switch will glow blue.
2. Turn on the Redmike Share by sliding the switch to the up position.
3. Grip the barrel in the center section. **Avoid covering the infrared emitters circling the base of the screened microphone element. This could interrupt signal transmission.**
4. While speaking in a normal voice, increase the B volume level of the amplifier until your voice is barely audible.

REMEMBER: This equipment is designed to supplement and distribute the user's voice so they are able to speak in a conversational tone. Having the volume set too high will result in feedback and listener fatigue.



5. AUDIO INTEGRATION

The next step in setting up your system is to connect it to the other multimedia devices in your classroom. You may have a computer, television, DVD/VCR player, a visual projection system or other devices. Below are instructions on how to integrate TV/VCR, CD/DVD or computer directly into the amplifier.

1. Ensure the power is switched off and the audio input volume controls are turned all the way down.
2. Connect the appropriate RCA or 3.5mm audio cable (not included) from the audio source into the corresponding input jack on the rear panel of the amplifier.
3. With both the amplifier and the audio source power on, adjust the corresponding volume control on the amplifier until the desired level is achieved.

One Possible Set-up

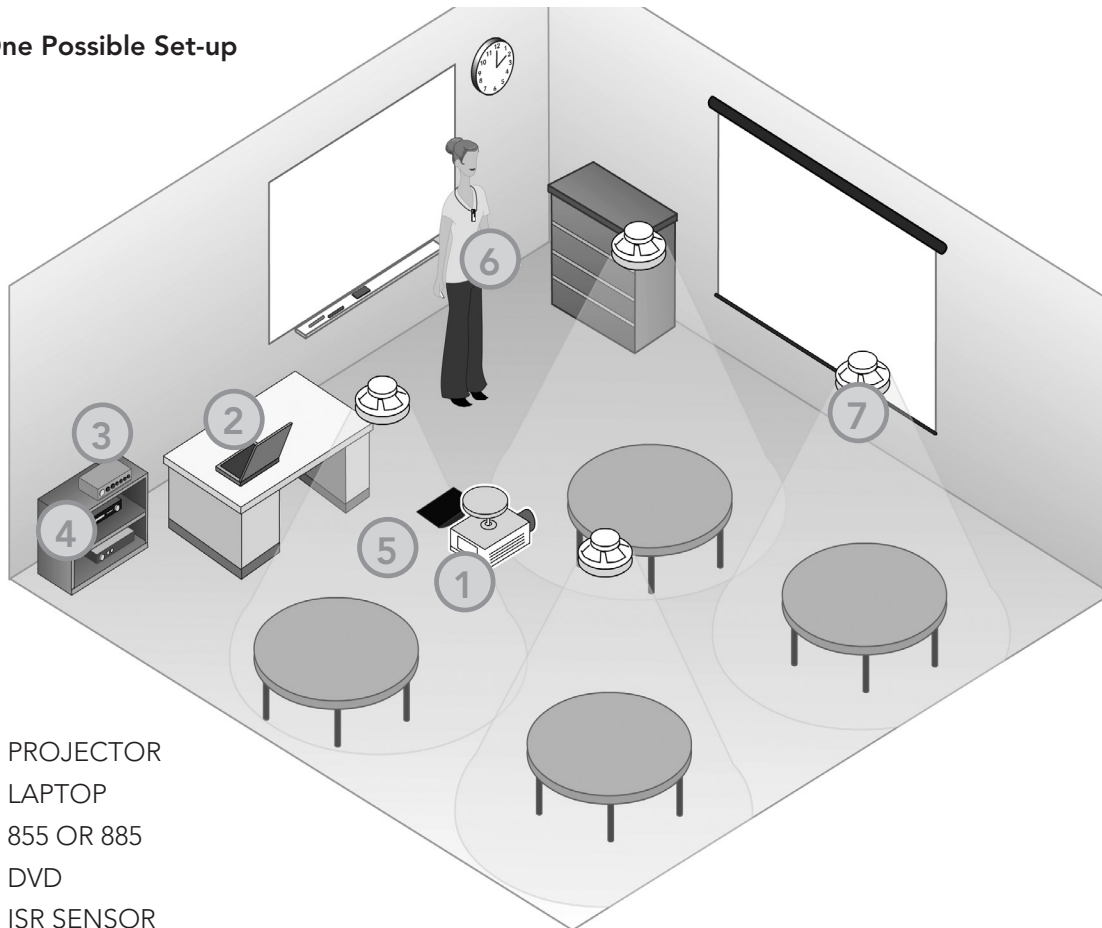

1. PROJECTOR
2. LAPTOP
3. 855 OR 885
4. DVD
5. ISR SENSOR
6. TEACHER'S MICROPHONE
7. SPEAKERS

SECTION 6:

INSTALLATION INSTRUCTIONS FOR OPTIONAL EQUIPMENT

1. PAGEFIRST INSTALLATION FOR 855/885

The following components are included when the PageFirst option is purchased as an add-on:

- PageFirst sensor clip with wire pigtail (PFSC)
- 50' length of wire with connector
- 2 wire nuts

1a. LOCATE PAGING SPEAKER AND SENSOR CLIP

If possible, the paging sensor should be hung around the lead wires that are connected directly to the speaker. If it is a sealed ceiling speaker where only the 70-volt wire is accessible, connect to the exposed 70-volt wires.

1. Locate the paging speaker in the classroom. NOTE: PageFirst does not work with telephone or IP-based intercom systems.
2. Locate the PageFirst sensor clip. This clip is designed to hang around the wire connected to the paging speaker.

1b. CONNECTING SENSOR TO SPEAKER WIRE

1. Gain access to the back of the speaker either up in the ceiling or on the wall. NOTE: there is no need to disconnect any wires.
2. Unclip and open the top loop of the PageFirst sensor. Hang it around one of the lead wires connected to the paging speaker and clip it back together (Figure 1).

Figure 1: Hanging the Sensor Clip

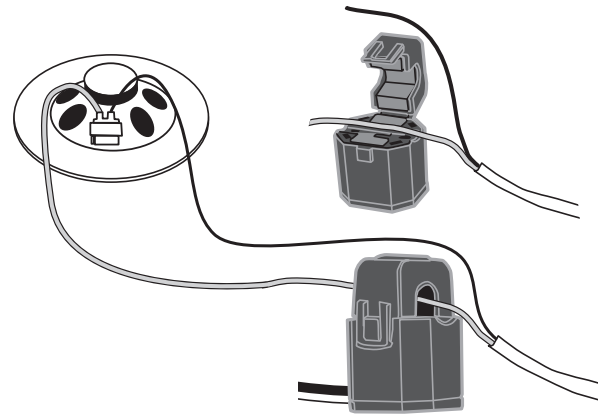

1. PAGEFIRST INSTALLATION CONT'D

1c. CONNECT PAGEFIRST SENSOR TO AMPLIFIER

The sensor needs to be hard-wired back to the amplifier.

1. Insert the euro-block connector of the wire into the PageFirst input jack on the amplifier. Secure with a screw driver by tightening the screw on the left and right sides of the terminals. (Figure 2.3)
2. Route the wire from the amplifier to the paging speaker. NOTE: when routing wire, make sure to secure to the building structure, as electrical and building codes require.
3. If the system mutes during times when a page is not being broadcast, turn the sensitivity down by turning the ADJ knob counterclockwise, and test again.

Figure 2:
Connecting Pagefirst to amplifier

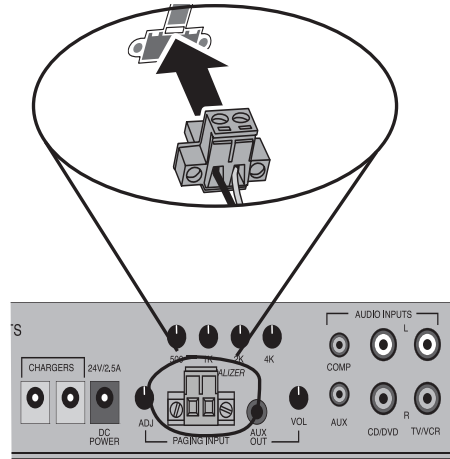

1d. TESTING PAGEFIRST

A page will need to be broadcast through the system to verify PageFirst is properly sensing the audio signal.

1. Turn on the system and begin speaking.
2. Broadcast a page through the central paging system.
3. The system should mute as the page is broadcast. When the broadcast is over, the system should amplify the mic as normal.
4. While walking around the room, continue talking into the microphone. Verify that the system is not muting during times there is no page being broadcast.

Figure 2A:
Securing connector to amplifier

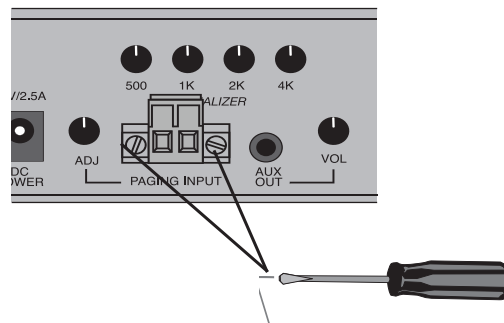

1e. ADJUSTING THE SENSITIVITY

1. The sensitivity adjustment (labeled "ADJ") is pre-set to the 9 o'clock position. This should be the appropriate setting for the majority of installations.
2. If the system does not mute while the page is being broadcast, turn the sensitivity adjustment up by turning the ADJ knob clockwise and test again.

2. INITIAL SET-UP: OPTIONAL IR MEDIA CONNECTOR

1. Turn off the second microphone.
The iR Media Connector uses the same channel (channel B) as the optional second microphone (Redmike or Redmike Share). As a result, they cannot be used simultaneously. If you have a second microphone, turn it off before transmitting audio from the iRMC.

NOTE: If you adjust the CH B volume on the classroom audio system, you will also be changing the volume for your second microphone. Return the CH B volume knob to the original position before turning the second microphone back on.

2. The iR Media Connector volume is preset for most standard audio signals. If you need to turn the volume up or down, follow this procedure:

A. Adjust the volume at the computer, television, or other audio source if possible.



B. If the audio source does not have a volume control (such as many DVD players) adjust the volume at the iRMC.

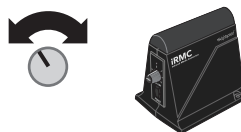

C. If the first two options do not give optimum volume level, the last place to adjust the volume is the CH. B Volume on the amplifier.



2a. OPTIONAL IR MEDIA CONNECTOR AUDIO INTEGRATION

The iRMC is designed to integrate with the Cat 855 or 885 and multiple audio sources, allowing other instructional technologies to be clearly heard throughout the classroom.

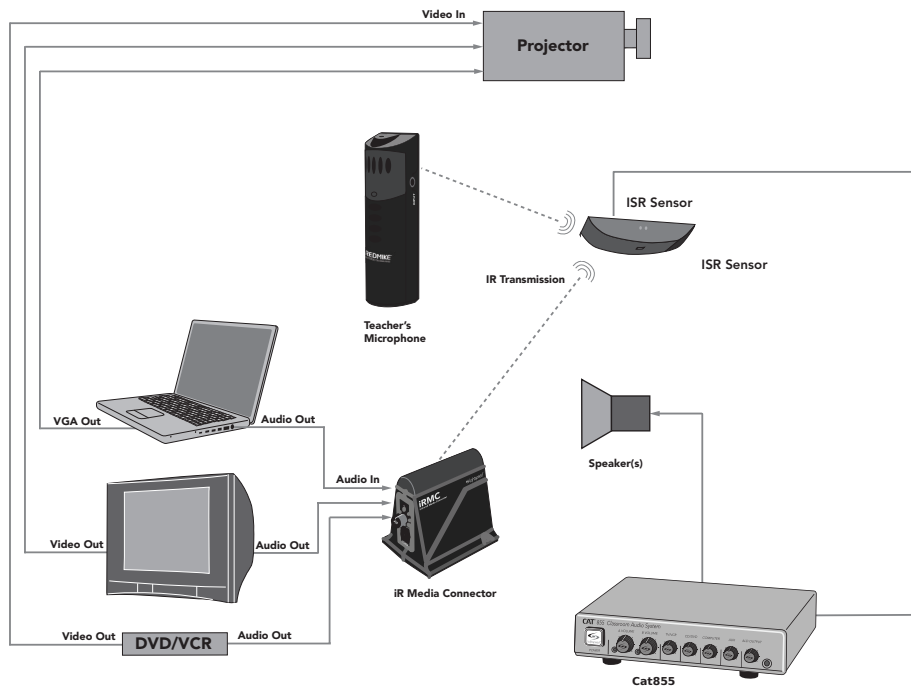

OTHER OPTIONAL ACCESSORIES

Other Optional Accessories

IRMC2	Infrared Media Connector
TK250M	Noise-canceling headset microphone
TCC7	Charging cable for Redmike Share
RCA6	6' dual RCA audio cable
MSC3535	3.5mm to 3.5mm stereo audio cable

7. Troubleshooting

6. Installing Optional Equipment

5. Set Up & Integration

4. Speaker Location & Installation

3. iR Sensor Location & Installation

2. Installation Planning

1. Overview

3. CAT 855/885 - MULTIPLE SENSOR INSTALLATION INSTRUCTIONS

For large room applications or rooms needing improved IR coverage, the Cat 855 & 885 utilize an ISR module for the primary sensor/receiver and an SR70F IR sensor for any additional sensors needed. The SR70F IR sensors are daisy-chained off the main ISR module via an F-style coax connector on the back of the ISR module. A maximum of (1) ISR module with up to (3) SR70F IR sensors may be used on a system.

3a. DETERMINE THE NUMBER OF ISR SENSORS NEEDED

The ISR module will cover approximately 1600 Sq ft in a normal sized classroom with up to 12 ft ceilings. If the room has high or sloped ceilings, large dark surfaces such as carpet or tables (IR absorbing), this range may be reduced. If the adjacent walls are further apart than 30 ft, this too can effect the coverage of the ISR module. When calculating the number of sensors needed, using a more conservative number of one sensor per 1200 sq ft is prudent. Utilizing the services of a Lightspeed representative for determining if the room is acceptable for an IR based system, as well as number of sensor that will be required, is highly recommended when a system is to be installed in rooms other than a standard cube. (Customers outside the U.S should consult with their local reseller.)

3b. MOUNT ISR AND ADDITIONAL SR70F SENSOR(S)

Evenly space the ISR module and additional SR70F(s) in the coverage area and mount them to the wall or the ceiling as outlined in the "INSTALL ISR Module" section of this manual.

Figure 2: 855/885 with multiple sensors

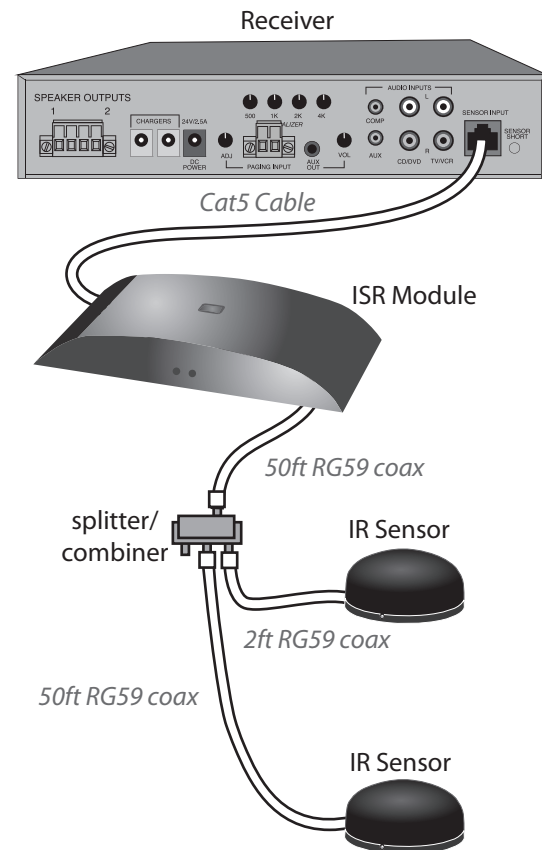

Maximum IR sensors off of ISR module = 3

3. CAT 855/885 - MULTIPLE SENSOR INSTALLATION INSTRUCTIONS cont'd

3c. ISR CONNECTION FOR 855/885

1. Attach a 50ft Cat5e cable from the "Sensor Input" on the back of the amplifier and run the cable using standard wiring methods acceptable to local codes up to the RJ45 connector on the back of the ISR module (See figure 2). Neatly coil the excess wire into a service loop and hide above ceiling or behind a soffit if possible. If not, cut to length and add a new F-style connector.
2. Attach a 50 ft RG59 coax to the F-style connector on the back of the ISR module and re-attach the ISR module to the installed mounting clip.
3. Run the RG59 coax cable to the first SR70F IR sensor using standard wiring methods acceptable to local codes. If only (1) SR70F IR sensor is needed, connect the RG59 coax directly to the SR70F connector pigtail and stop here. Handle excess wire as in step 1.
4. If more than one SR70F is needed to be installed, connect the RG59 coax coming from the ISR module to the input of a Lightspeed HS3 splitter/combiner.
5. Connect a 2ft RG59 coax to one of the output ports on the HS3 and connect the other end to the F-connector pigtail of the first SR70F IR sensor.
6. Connect another 50ft RG59 coax to one of the HS3 splitter combiner outputs and run the cable down to the second SR70F IR sensor. Handle excess wire the same as in step 1.
7. If another IR sensor is to be added repeat step 5. Keep in mind that a maximum of (3) SR70F IR sensors may be added to a system. (See figure 2)

SECTION 7:

TROUBLESHOOTING

COMMON PROBLEMS AND SOLUTIONS

Note: Most problems are directly related to low battery power. Please run through the “Battery Check” items first. For remaining troubleshooting, use known good, fully-charged batteries.

ALL PROBLEMS: Most Problems are related to low battery power.

SOLUTION: Battery Check

- Confirm batteries are charged each night.
- Confirm proper batteries are used. The Redmike requires the Lightspeed NH2A27 rechargeable sensing battery for proper charging. The Redmike Share uses the NH2APK rechargeable battery pack.
- Make sure the microphones are turned off while charging so a full charge is attained. Full charge will last eight hours.
- Inspect the battery contacts. Clean and adjust if necessary.

PROBLEM: Hearing Static

SOLUTION: Follow these steps to eliminate static.

- Ensure sensor is in optimum location (refer to sensor placement in this manual). A single sensor will cover a 1600 sq. ft. enclosed classroom.
- Ensure that no other Redmike or Redmike Share is operating on the same channel.
- If the optional iR media connection

is in use, set the microphone to channel A.

PROBLEM: Low Volume or Feedback

SOLUTION: Follow these steps to eliminate low volume or feedback.

- Ensure microphone is positioned appropriately, just below the collar bone.
- Check volume level on the amplifier. If the volume is too high, feedback will occur. Adjust accordingly.
- Adjust the volume level on the back of the optional Redmike VC.

PROBLEM: No Sound From Speaker

SOLUTION: Follow these steps to produce sound from speakers.

- Turn the amplifier on. Confirm that the POWER light located on the front panel switch is on.
- Confirm signal is being received. The IR signal light will be red, indicating a signal is being received.
- Confirm that Redmike is turned on. There will be a blue LED on the microphone to indicate it is powered on.

If you review these instructions and still have questions, write down the serial number and model number of your system and call Lightspeed Technical Services at 800.732.8999, 5 a.m. – 5 p.m., PST. Customers outside the U.S. should contact their local reseller.

This page intentionally left blank.

This page intentionally left blank.



A C - I G C A T - C

LIGHTSPEED TECHNOLOGIES

11509 SW HERMAN ROAD / TUALATIN, OR 97062
TOLL FREE: 800.732.8999 / PHONE: 503.684.5538 / FAX:
503.684.3197
LIGHTSPEED-TEK.COM

IG0456US01-3