



# 955 Access

Instructional Audio System



User Manual





# Table of Contents

## OVERVIEW

- 3** Important Safety Instructions
- 4** System Components and Unpacking
- 5** Optional Components
- 6** Optional Speakers
- 7** 955 Access Controls and Indicators
- 8** 955 Access Controls and Indicators
- 9** Flexmike Controls and Connections
- 10** Microphone Cradle Charger

## SET-UP & OPERATION

- 11** Connecting the Power Supply
- 12** Setting Up the Flexmike
- 13** Charging the Flexmike
- 14** Daily Use of the Flexmike
- 15** Pairing your Microphone
- 17** Output Audio to Assistive Listening Device (ALD)
- 18** Using Your Microphone as a Wireless Audio Link
- 19** Audio Integration

## OPTIONAL COMPONENTS

- 20** Sharemike Controls and Connections
- 22** Media Connector Controls and Indicators
- 24** Media Connector Set Up and Operation
- 25** Connecting Media Connector to Audio
- 26** Pairing 955 Access to Media Connector
- 27** Using T3 Microphones

## MAINTENANCE & TROUBLESHOOTING

- 29** Flexmike Battery Replacement
- 30** Sharemike Battery Replacement
- 31** Troubleshooting
- 32** Tips for Optimum Audio Performance

## WARRANTY, SAFETY & SPECIFICATIONS

- 33** Five-Year Limited Warranty
- 34** Safety Warnings and Certifications
- 38** System Components
- 39** System Specifications



## OVERVIEW

# Important Safety Instructions

1. Do not use the apparatus near water.
2. Clean only with dry cloth.
3. Do not block any ventilation openings.
4. Do not install near any heat sources such as radiators, heat registers, stoves, or other apparatus (including amplifiers) that produce heat.
5. Do not defeat the safety purpose of the polarized or grounding-type plug. A polarized plug has two blades with one wider than the other. A grounding-type plug has two blades and a third grounding prong. The wide blade or the third prong is provided for your safety. If the provided plug does not fit into your outlet, consult an electrician for replacement of the outlet.
6. Protect the power cord from being walked on or pinched particularly at plugs, convenience receptacles, and the point where they exit from the apparatus.
7. Unplug this apparatus during lightning storms or when unused for long periods of time.
8. Refer all servicing to qualified service personnel. Servicing is required when the apparatus has been damaged in any way, such as power-supply cord or plug is damaged, liquid has been spilled or objects have fallen into the apparatus, the apparatus has been exposed to rain or moisture, does not operate normally, or has been dropped.
9. When the mains plug or appliance coupler is used as the disconnect device, it shall remain readily operable.
10. Please keep the unit in a good ventilation environment.
11. **WARNING:** To reduce the risk of fire or electric shock, do not expose this apparatus to rain or moisture.
12. Apparatus shall not be exposed to dripping or splashing and no objects filled with liquids, such as vases, shall be placed on the apparatus.
13. **WARNING:** Battery pack shall not be exposed to excessive heat such as sunshine, fire or the like. (1) The battery pack is not serviceable. Do not open, disassemble, or service any battery pack. (2) Do not crush or cut or puncture the internal battery cell. (3) Do not short-circuit the battery, or expose it to water or other liquids. (4) Do not touch the internal battery cell for any reason. (5) Keep the battery away from fire or a hot oven. Do not dispose of the battery into fire or a hot oven. (6) Keep the product with battery away from extremely low air pressure or high temperature surrounding environment. Battery subjected to extremely low air pressure may result in an explosion or the leakage of flammable liquid or gas. (7) Stop using the battery pack if it is damaged, or if you notice any discharge or the buildup of foreign materials on the battery contacts. (8) Do not put the battery in trash that is disposed of in landfills. When disposing of the battery pack, comply with local ordinances or regulations.
14. **CAUTION:** Risk of explosion if battery is replaced by any battery other than Lightspeed Part # L3.7V



# System Components and Unpacking

The standard configuration of the 955 Access system includes:

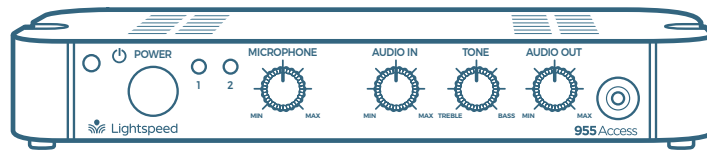

## 955 Access

Instructional Audio System  
and Power Supply

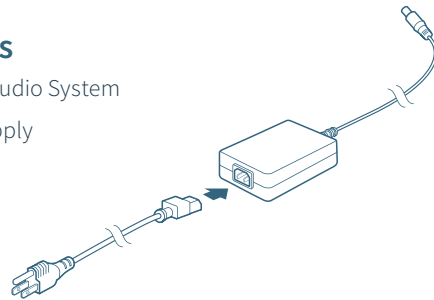

## Flexmike

Teacher Microphone

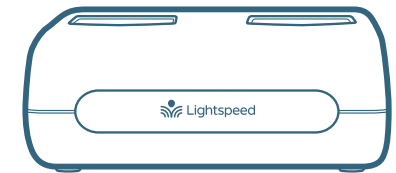

## Microphone Cradle Charger

and Power Supply

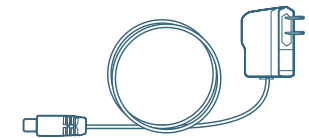

**TIP:** The 955 Access and wireless microphones are paired together at the factory. Please keep all components together as a system. Moving them from one system or room to another will result in the need to re-pair them to function.



# Optional Components

Optional equipment which may be part of your 955 Access system



## Sharemike

Student Microphone *(Optional)*

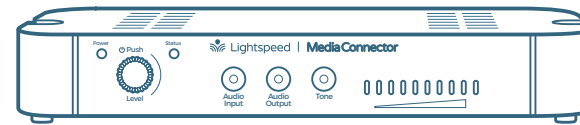

## Media Connector

and Power Adapter

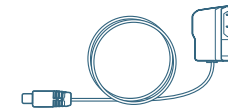



# Optional Speakers

Systems can be configured with a variety of ceiling or wall-mounted speakers, including these Lightspeed models.

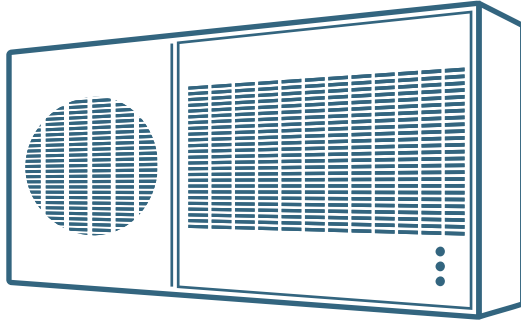

**TCQ** (x 1)  
Hybrid Ceiling Speaker

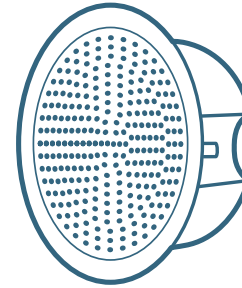

**DRQ** (x 4)  
Ceiling Speaker

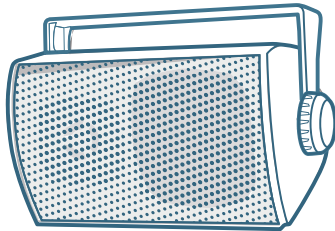

**WMQ** (x 4)  
Wall Speaker  
Available in U.S. and Canada only

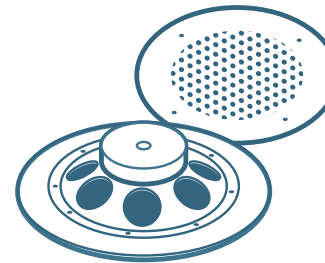

**4JCS** (4 per room)  
Plenum Ceiling Speaker  
Available in U.S. only



# 955 Access Controls and Indicators

## FRONT PANEL

1. **POWER LIGHT:** This light will turn blue when power is on.
2. **POWER BUTTON:** Press and hold this push button to turn the system power on or off.
3. **MICROPHONE VOLUME CONTROL:** Controls the volume level of the microphones.
4. **AUDIO IN VOLUME CONTROL:** Controls the volume level of the audio sources connected to the audio inputs on back of the 955 Access.
5. **TONE CONTROL:** Adjusts the audio tone adding more bass or treble for a more rich or more crisp tone.
6. **AUDIO OUT VOLUME CONTROL:** Controls the volume level of the audio output
7. **AUDIO OUTPUT JACK:** 3.5mm stereo connector for connecting to an assisted listening device (ALD) or to a computer for recording.
8. **MIC 1 & MIC 2:** Microphone link and registration indicators.
  - Solid green indicates an audio link has been established.
  - Flashing amber indicates registration is in process.
9. **SYSTEM ID LABEL:** On bottom of unit (not shown) to identify it with registered components.

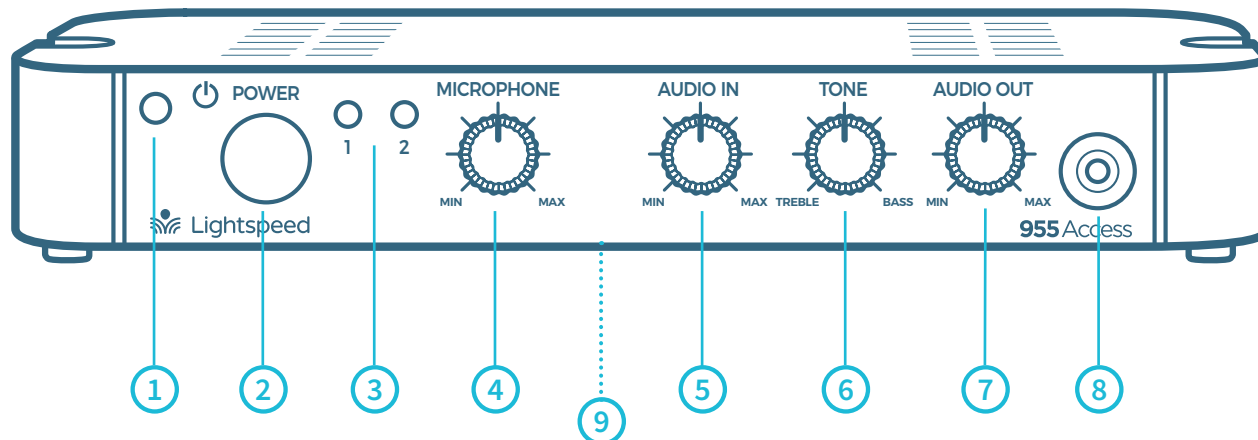



# 955 Access Controls and Indicators

## BACK PANEL

1. **REGISTRATION:** Press this button if there is a new component, such as a microphone, to be registered.
2. **AUDIO INPUTS:** 3.5mm stereo connectors for connecting classroom audio sources to be played through audio system.
3. **PAGING ADJ:** Use the ADJ control to adjust the sensitivity of PageFirst if needed.
4. **PAGEFIRST INPUT:** Connect the input from the optional PageFirst sensor here when interfacing with a building's paging system.
5. **SPEAKER OUTPUTS:** This euro-block connector is used to connect the 955 Access to the loudspeaker(s). Up to two 8-ohm speakers can be connected to each output.  
**Note:** Wiring to these terminals should follow the Class 2 wiring methods as outlined in the National Electric Code.
6. **DC POWER:** Plug the power supply (24V/2.5A) into this jack.

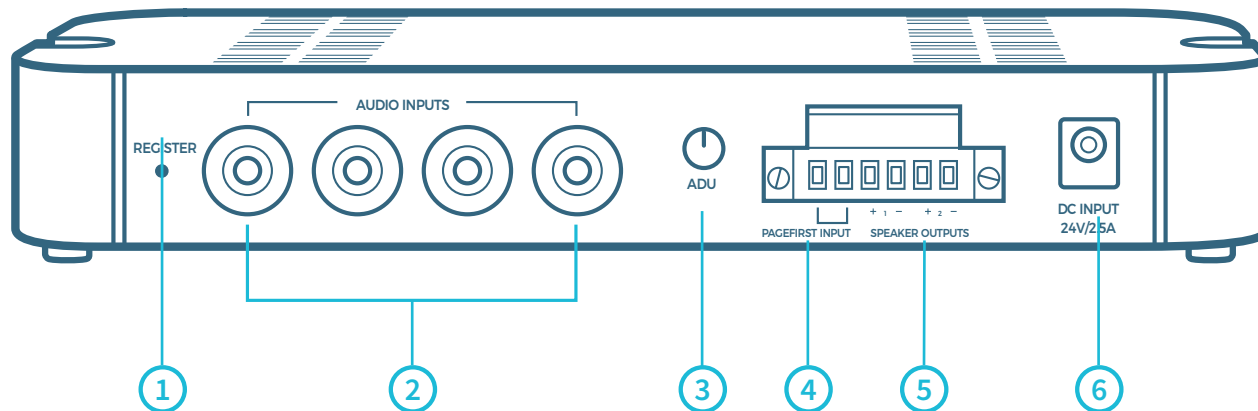





# Flexmike Controls and Connections

- POWER/MUTE SWITCH:** Press and hold to power on, press to mute or talk, press and hold to power off.  
**Blue light:** Talk  
**White light:** Mute
- IR TRANSMITTER:** For pairing to base unit.
- MIC 1 STATUS:** lighted to indicate microphone is registered as Mic 1  
**White: solid** = Normal operation  
**White: flashing** = Linking in progress
- MIC 2 STATUS:** When using a second microphone, this LED is lighted to indicate microphone is registered as Mic 2  
**White: solid** = Normal operation  
**White: flashing** = Linking in progress
- MICROPHONE VOLUME UP/DOWN**
- POWER STATUS LIGHT**  
**Red light:** In operation, turns red to indicate low battery.  
**White light:** Normal operation  
  
When charging in Cradle Charger:  
**Red light:** Charging  
**Green light:** Charging complete
- EARBUD/MIC CONNECTION:** Connect the earbud for monitoring for use with Pods only, also for use with optional EMA (earset) and LMA (lapel) microphones.
- LANYARD INTERFACE:** Insert the lanyard into this hook to wear the Flexmike.
- BATTERY:** Remove the battery to replace the rechargeable battery pack.
- USB INPUT:** Connect audio source to send to 955 Access. USB input can also be used for charging.

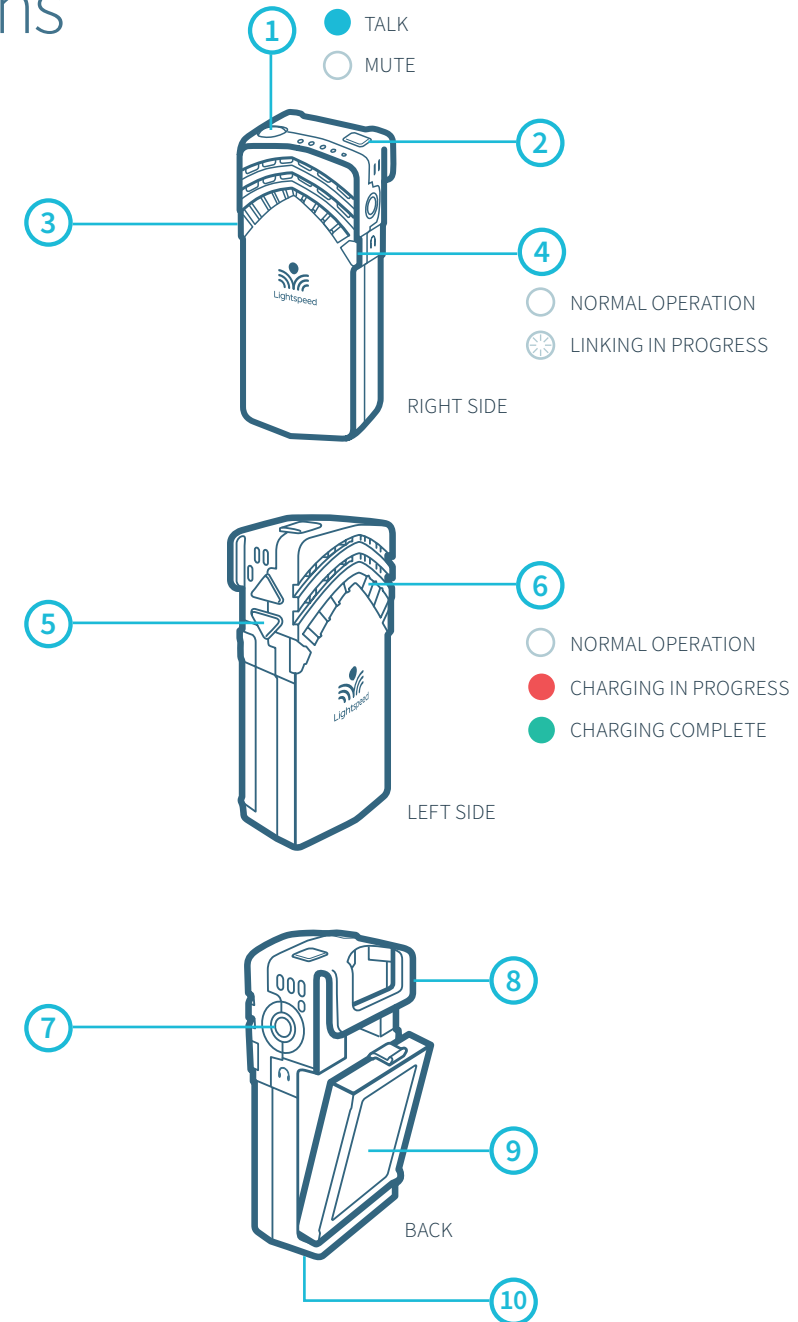



# Microphone Cradle Charger

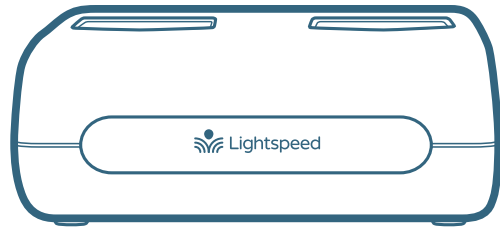

**DC POWER PORT:** Connect the 5V/1.0A DC power cord

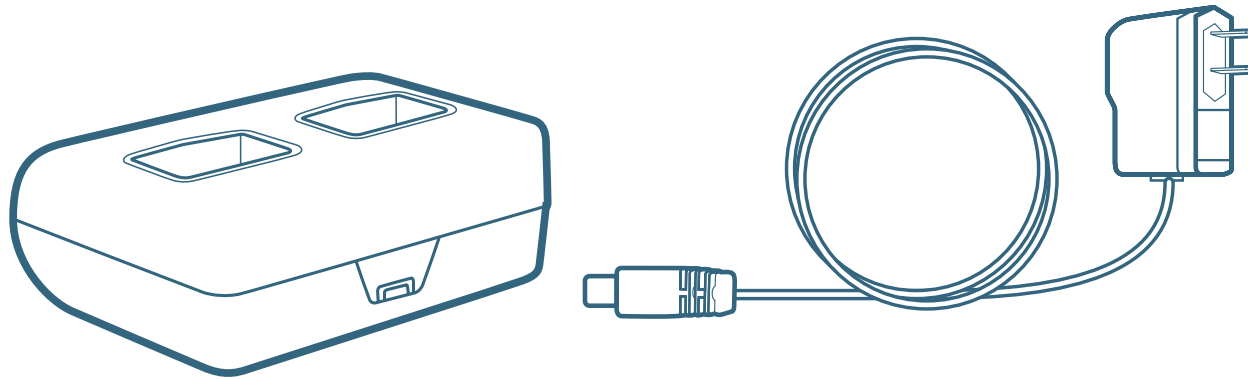



## SET-UP & OPERATION

# Connecting the Power Supply

- Locate the power supply and AC power cord. Connect the AC power cord into the DC power supply.
- Insert the DC connector into the “DC INPUT” on 955 Access and plug the other end to an electrical outlet.
- The 955 Access automatically powers on and the white power light on the front panel will appear.

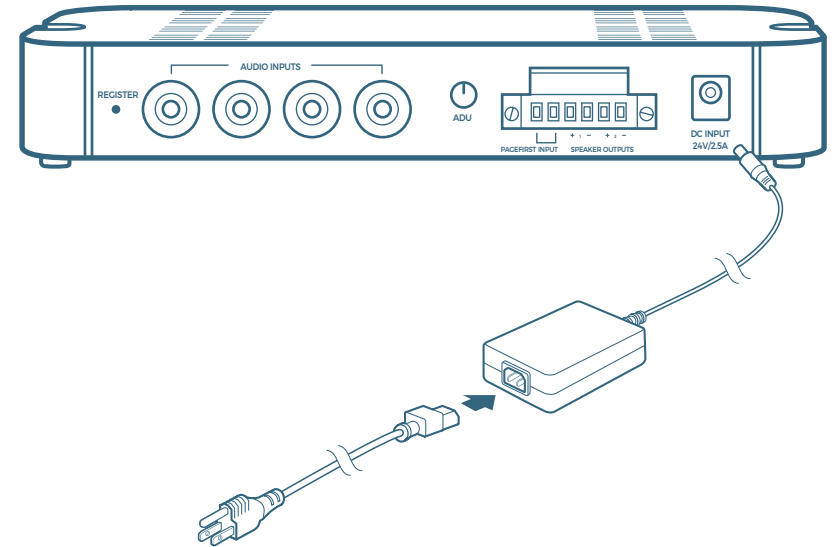



# Setting Up the Flexmike

Once the Flexmike is charged, follow these steps for use.

1. Remove the Flexmike from the charger and put it on by connecting the magnetic clasps behind your neck. Adjust the lanyard so that the top of the Flexmike aligns with the collarbone.
2. The Flexmike will automatically power on and mute when it is removed from the charger.
3. The microphone volume on the Flexmike is set at the factory to the midpoint. It is adjusted by the up/ down buttons on the side of the mic.
4. While speaking in a normal voice, fine tune the microphone volume. Proper volume level should be as follows:
  - Your voice should be clearly heard by another person on the other side of the room.
  - You should barely be able to hear your own voice.
  - There should not be any audio “feedback” or squealing outside of 2-3 feet (if there is, turn the volume down slightly).

**REMEMBER:** This equipment supplements the user’s voice so they are able to speak in a conversational tone. Having the volume set too high will result in feedback and listener fatigue.

- Once initial volume level is set, walk around the room and listen for overall audio quality.
- If further fine tuning is required, you may need to adjust the Tone Control on the front of the 955 Access.

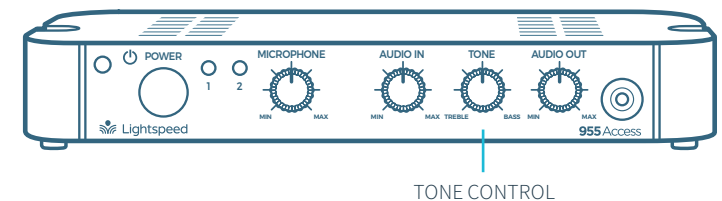
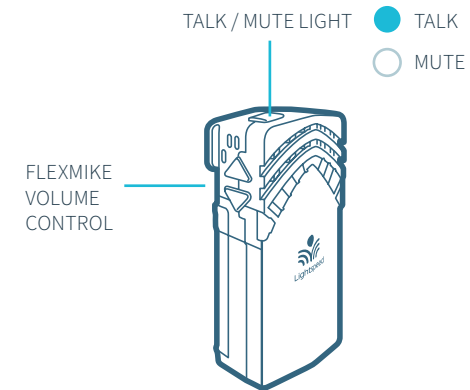
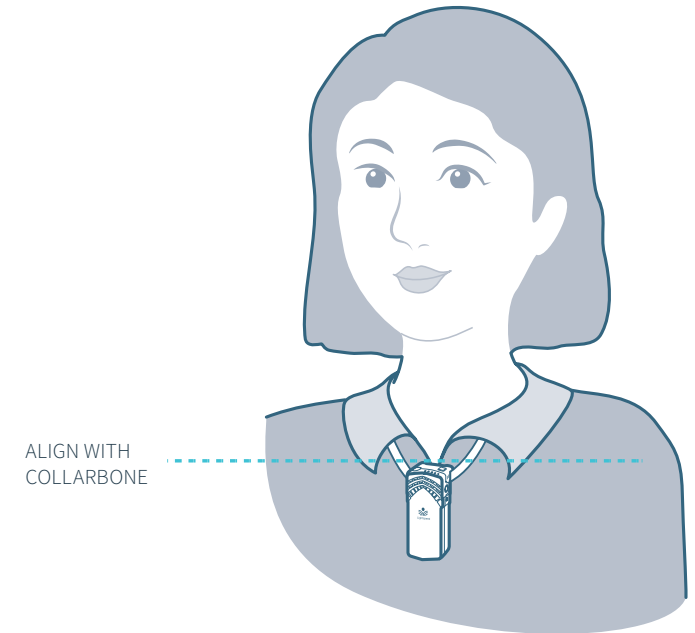



# Charging the Flexmike

## BEFORE USE, THE FLEXMIKE SHOULD BE CHARGED

It will take 5-6 hours for the Flexmike to obtain a full charge. A fully charged Flexmike will last for up to 8 hours of use. If microphones are used daily, they should be charged each night.

Replacement lithium polymer battery packs may only be purchased through Lightspeed (part # L3.7V).

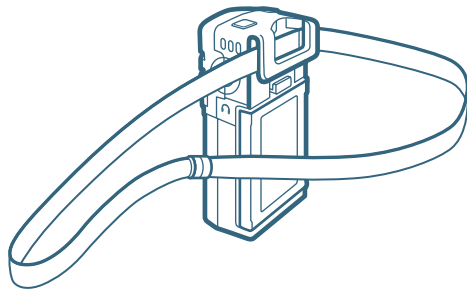

### ATTACH LANYARD

Hang the Flexmike on the lanyard opposite the magnetic clasp.

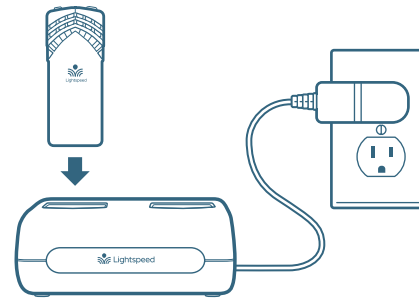

### CONNECT CRADLE CHARGER

Plug power cord into the cradle charger and then plug the AC end into an electrical outlet.

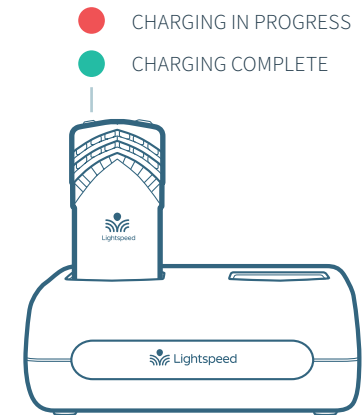

### CHARGE FLEXMIKE

Place the microphones into the cradle charger. The power status light will glow red when it is charging. When charging is complete, the power status light will glow green.

It takes about 5-6 hours to fully charge the microphone battery.



# Daily Use of the Flexmike

## 1. AT THE START OF THE DAY, REMOVE FLEXMIKE FROM THE CHARGER

- The microphone will default to the Mute position, the status light will turn to white.
- Place the microphone around your neck.
- Press the power/mute button. The light will turn blue, indicating the microphone is active and ready to use.
- Adjust volume with the UP/DOWN buttons if necessary.
- If Flexmike needs to be powered down for some time, press and hold the power button. To power Flexmike again, press and hold the power button until the power status light turns white.

## 2. PRIVATE CONVERSATIONS

- Mute the Flexmike during private conversations by momentarily pressing the power button. When muted, the blue light turns white.
- When conversation is over, momentarily press the power button again to unmute the Flexmike.

## 3. END OF DAY

- Place the Flexmike into the cradle charger and make sure the Power Supply is plugged in to an electrical outlet.
- The Flexmike will stay powered on during charging, but will automatically be muted.
- It is not necessary to turn off the 955 Access at end of day, but you may do so by pressing the power button on the front panel.
- If you do want to power it down, when Flexmike is removed from charging the next day, it will automatically power the 955 Access on.

POWER / MUTE BUTTON  
& STATUS LIGHT



VOLUME CONTROL

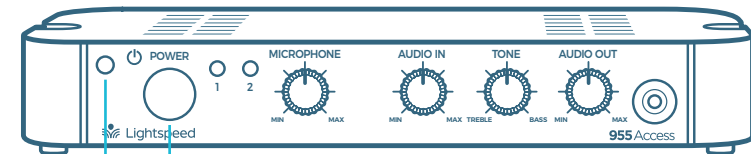
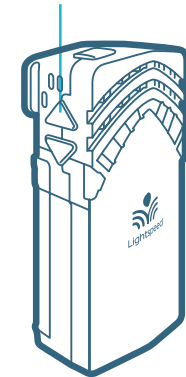

POWER  
STATUS  
LIGHT

POWER  
BUTTON



# Pairing your Microphone



Your system is shipped with microphones and base units pre-paired for quick and easy use. If, for any reason, you need to pair new components, follow this pairing process:

1

With a paperclip, push the register button on the back of 955 Access.



2

From a powered off state, press and hold the power button for five seconds until the mic 1 and mic 2 lights start flashing, then release the button and let the pairing process finish.

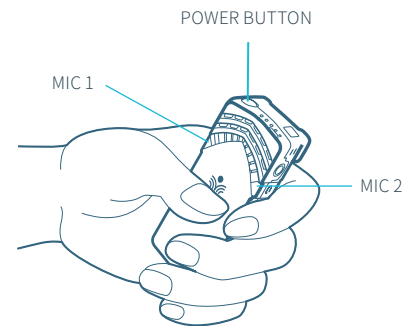

3

The "status" light on Access 955 will light up indicating the pairing process is complete. The mic 1 or mic 2 light on the microphone will stay illuminated.

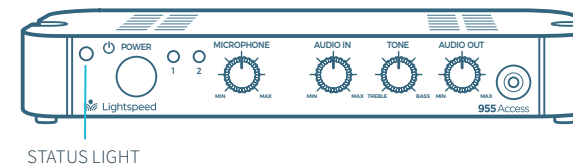



# Installing PageFirst Sensor *(optional)*

955 Access can interface with an independent classroom paging system.

When a page is broadcast, all audio from the system is muted, ensuring important school-wide messages are not missed. Please note that PageFirst is not compatible with telephone or IP-based paging systems.

How it works:

1. PageFirst sensor clip is hung around a lead wire attached to the classroom paging speaker.
2. The clip is hard-wired to the amplifier.
3. As a page is broadcast, the sensor clip detects the audio signal through induction and immediately mutes the amplifier.
4. When the page is over, the audio from the amplifier returns to normal volume level.

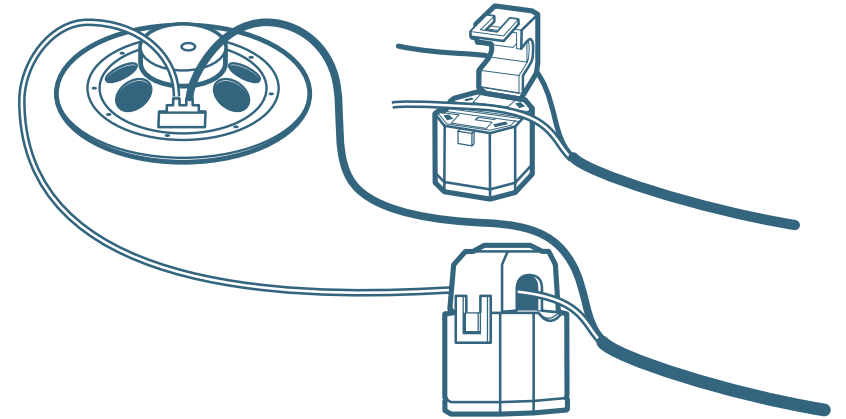





# Output Audio to Assistive Listening Device (ALD)

1. Press the Audio Output Selector first, then turn the volume control on the front panel all the way down (fully counterclockwise).
2. Determine the type of audio input jack on the ALD as manufacturers' products differ in connector size and shape. Many require a 3.5 mm to 3.5 mm patch cable (part# MSC3535, not included).
3. Connect a patch cable from the ALD microphone jack or AUX input to AUDIO OUT jack on the front of the 955 Access.
4. With the 955 Access and ALD turned on, speak into the Flexmike and slowly adjust the corresponding volume control on the 955 Access until the appropriate audio level is obtained in the ALD.
5. It may be necessary to adjust the volume on the ALD to achieve appropriate volume level.

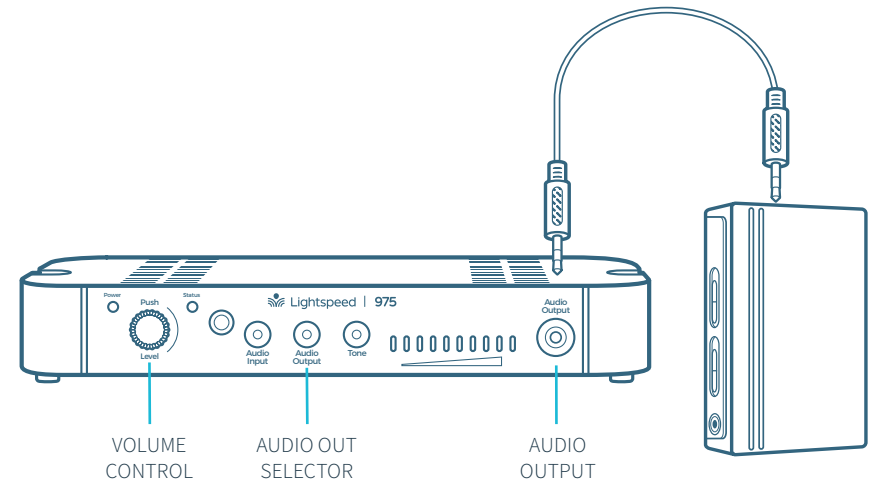



# Using Your Microphone as a Wireless Audio Link

You can connect your 2nd microphone to your computer's USB port to enable a wireless 2-way audio link.

**SEND AUDIO FROM THE COMPUTER** to the 955 Access to ensure all audio from the computer (videos, video conferencing, audio books, music, etc) can be played through the Lightspeed 955 Access system and speakers.

**SEND AUDIO TO THE COMPUTER** from the 955 Access to ensure the teacher's Flexmike and any student microphones are clearly picked up by a video conferencing solution.

1. With the appropriate USB cable (USB-C for Flexmike/Sharemike) connect your microphone to your computer's USB port. This will also power/charge your microphone.
2. Open sound settings on your computer:
  - Select Lightspeed Audio as the Output source to send all computer audio to the 955 Access system
  - Select Lightspeed Audio as the Input source to use the Lightspeed microphones as the computer microphone audio for video conferencing and recording applications.
3. You may also need to select Lightspeed Audio as the speaker and microphone audio in your video conferencing application the first time you use it.

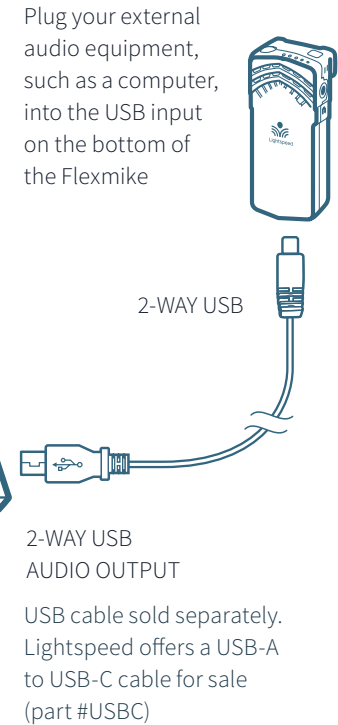
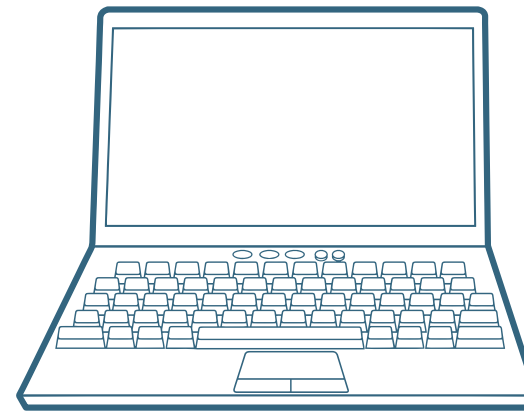

**TIP:** If your system includes two Flexmikes, you can use one mic for instruction and the second mic to transmit audio through the system.



# Audio Integration

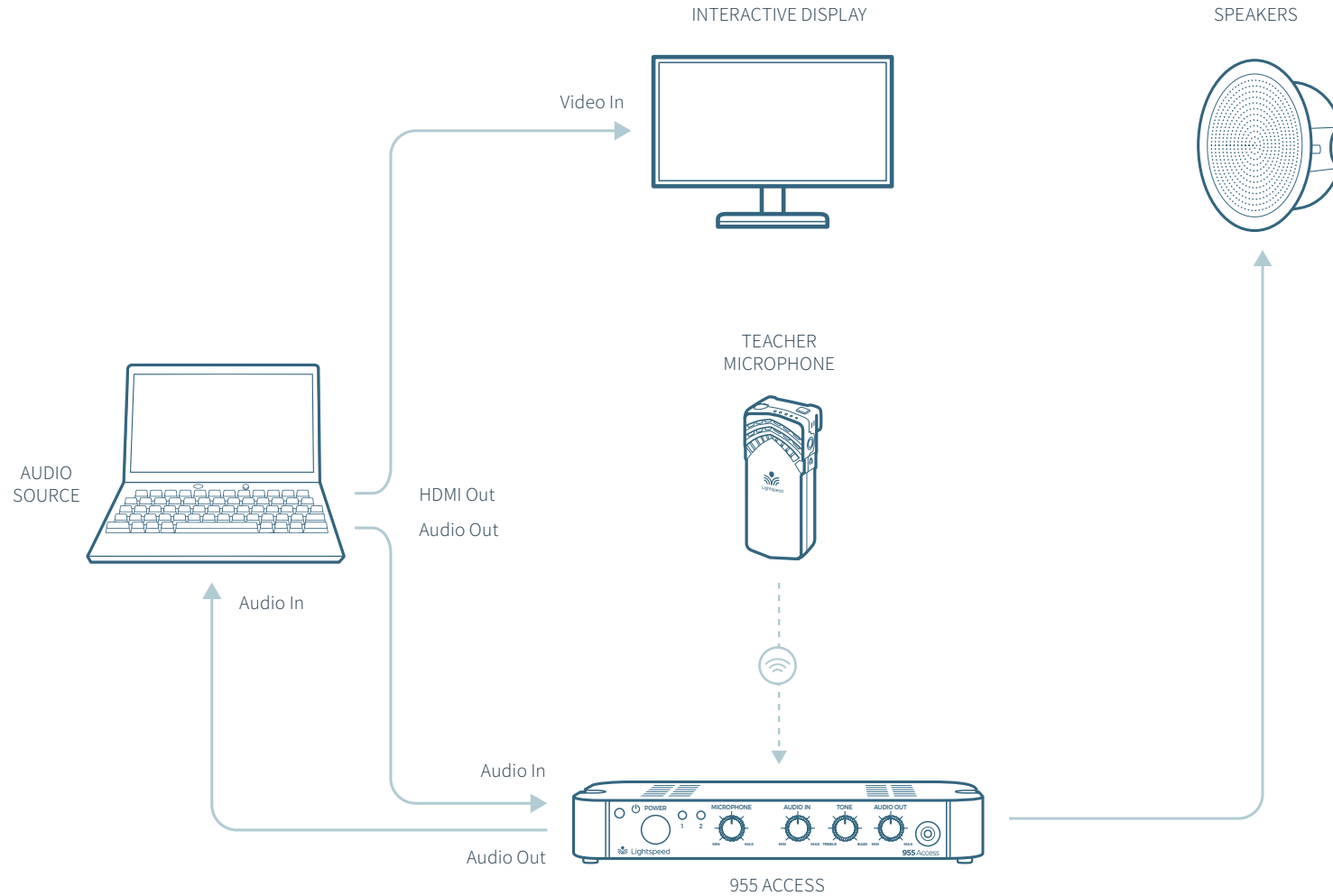



## OPTIONAL COMPONENTS

# ShareMike Controls and Connections

- POWER BUTTON**
- POWER STATUS LIGHT**  
**Red light:** During operation, turns red to indicate low battery  
**White light:** Normal operation  
  
When charging in Cradle Charger:  
**Red light:** Charging  
**Green light:** Charging complete
- MIC 1 STATUS:** Lighted to indicate microphone is registered as Mic 1  
**White: solid** = Normal operation  
**White: flashing** = Linking in process
- MIC 2 STATUS:** Lighted to indicate microphone is registered as Mic 2  
**White: solid** = Normal operation  
**White: flashing** = Linking in process
- MUTE/TALK STATUS LIGHT**  
**Blue: solid** = Talk  
**White: solid** = Mute
- MICROPHONE VOLUME UP/DOWN**
- USB INPUT:** Connect audio source to send to 955 Access. USB input can also be used for charging.
- IR TRANSMITTER:** For pairing to base unit
- AUDIO INPUT:** Plug a laptop or other audio device into this jack to wirelessly transmit the audio signal to be played through the system.
- VOLUME LOCK:** Disables volume controls.

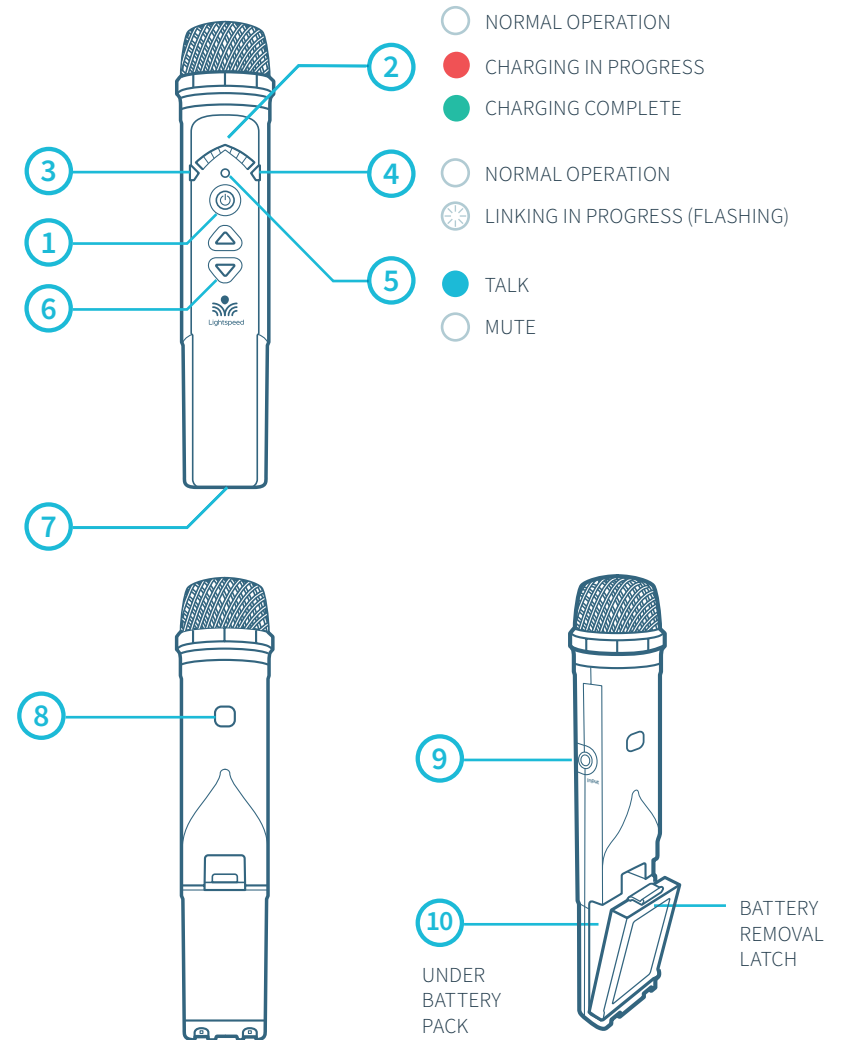



# ShareMike: Charging

1. Make sure the charger is plugged into a wall outlet.
2. The power status light on the microphone will glow red to indicate charging.
3. Leave the ShareMike in the charger overnight to obtain a full charge. It takes about 5-6 hours to fully charge the battery. The light will turn green when charging is complete.

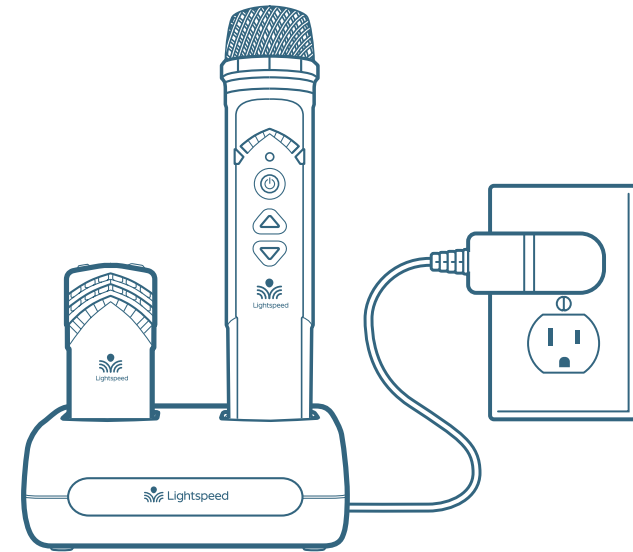
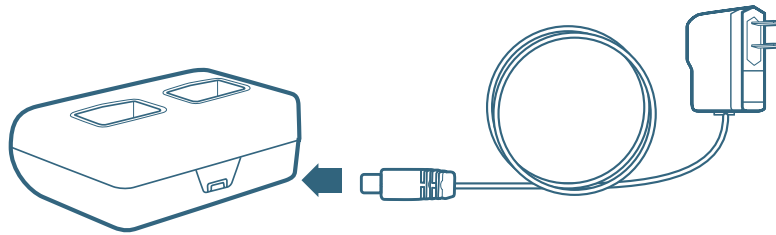

**PLEASE NOTE:** The 955 Access and microphone(s) are paired together at the factory and all components should be kept together as a system. Moving them from one system, or room, to another will result in the need to re-pair.



# Media Connector Controls and Indicators (Optional)

## FRONT PANEL

1. **POWER LIGHT**  
**White light:** Power on
2. **POWER BUTTON / VOLUME ADJUSTMENT:** Press this button to turn the system power on or off. This also functions as an adjustment knob for the volume and tone depending on the mode selected (see 4, 5, 6 below).
3. **STATUS LIGHT:** Microphone link and pair indicators.  
**Solid blue:** Microphone(s) is paired to the system  
**Off:** Microphones are not paired to the system
4. **AUDIO INPUT VOLUME SELECTOR:** Selects Volume as the mode for the adjustment knob (2) for the audio sources connected to the audio inputs on the back of the Media Connector.
5. **AUDIO OUTPUT VOLUME SELECTOR:** Selects Volume as the mode for the adjustment knob (2) for the audio device connected to the audio output jack on the back of the Media Connector.
6. **tone SELECTOR:** Selects Tone as the mode for the adjustment knob (2) for the microphone. This adjusts the bass or treble that is heard through the classroom speaker.

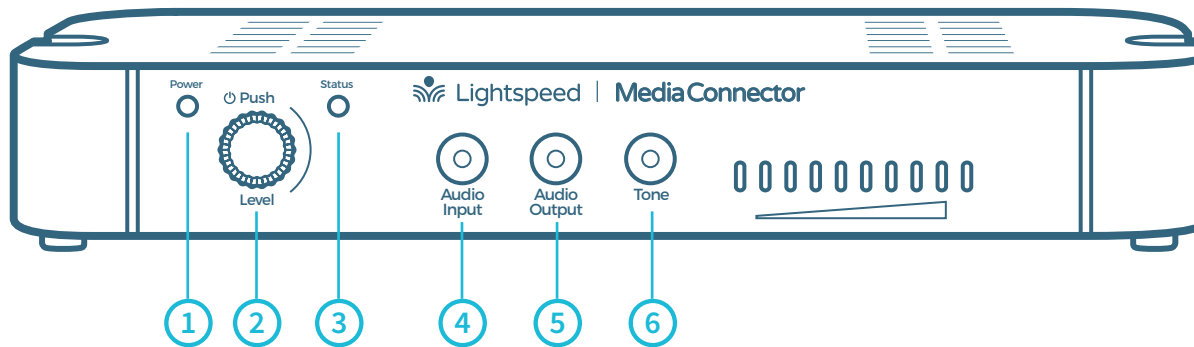



# Media Connector Controls and Indicators (Optional)

## BACK PANEL

1. **AUDIO INPUTS:** 3.5mm stereo connectors for connecting classroom audio sources to be played through audio system.
2. **AUDIO OUTPUTS:** 3.5mm stereo connectors for connecting to an assisted listening device (ALD) or to a computer for recording.
3. **USB INPUT:** Plug the USB-C end of the power cable into this USB port on the Media Connector.
  - The USB port supplies power to Media Connector when connected to the Media Connector power supply, or from a laptop.

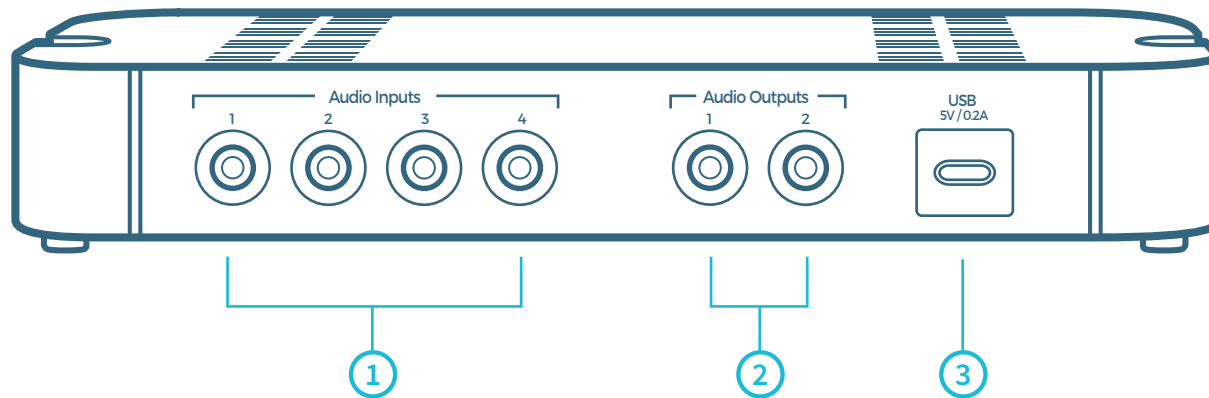



# Media Connector Set Up and Operation

## DETERMINE LOCATION

Media Connector is designed to be connected to the primary media source in the classroom, usually the computer or display panel.

## WALL MOUNT OR DESKTOP

The Media Connector can be placed on a table surface or wall-mounted.

- Choose a location that is convenient to the classroom audio sources and power supply.
- It should be located 3-6 feet off of the floor to allow for good transmission.
- Do not enclose in a metal cabinet or in a location where the signal will be obstructed.

**NOTE:** The Media Connector does not require a direct line of sight to the 955 Access. However it functions best when no obstructions are between the two devices.



## CONNECT TO POWER

Connect the USB power cord to a computer. Plug the USB cable into the USB input on the back of the Media Connector.

*or*

Use the USB power adapter to plug into a wall outlet.

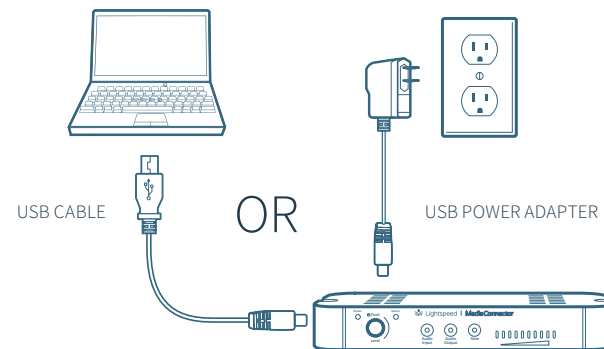





# Connecting Media Connector to Audio

## ANALOG AUDIO

Plug your external audio equipment (computer, tablet, video display, etc.) into one of the Audio input jacks using a 3.5mm audio cable.

Adjust the volume as needed by pressing the Audio Input selector and adjusting the level knob as needed.

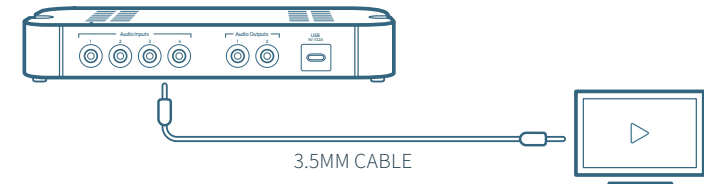

## SETTING THE VOLUME LEVELS

For recording, or to interface with an Assistive Listening Device, connect a 3.5mm cable to the Audio Output of the Media Connector to the microphone input on the device. Press the button for the desired level adjustment.

- Turn the knob to adjust volumes up or down for Audio Input/Output
- To adjust the Tone (bass/treble) of the speaker, press Tone and use the adjustment knob to turn the bass up and down





# Pairing 955 Access to Media Connector



Your system is shipped with microphones and base units pre-paired for quick and easy use. If, for any reason, you need to pair new components, follow this pairing process:

1

With a paperclip, push the register button on the back of 955 Access.

## 955 ACCESS BACK PANEL



2

On the Media Connector, press and hold the Tone selector button for 5 seconds to put it into pairing mode.

When the status lights are solid on both the 955 Access and Media Connector, pairing is successful.

## MEDIA CONNECTOR

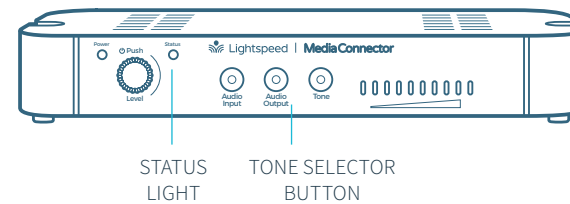

## 955 ACCESS FRONT PANEL

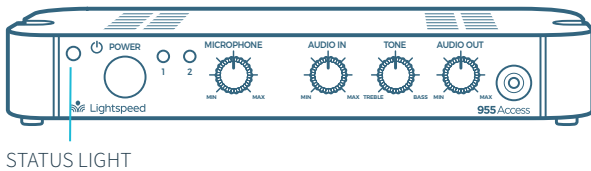



# Using T3 Microphones

T3 Microphones arrive paired to your new Lightspeed instructional audio system. If the microphones are being added to an existing audio system, they will arrive paired to the Access Link audio hub (see below).

During Tap-to-Talk student use, only a single T3 Microphone at a time can be connected and broadcast through the audio system. Up to 12 T3 Microphones can be paired to a single system, in addition the one or two Flexmikes or Sharemikes, which are always connected.

## IDENTIFY YOUR T3 MICROPHONES

T3 microphones appear very similar to standard Lightspeed microphones with a couple important differences:

- T3 functionality is indicated by a yellow-colored power status light.
- Both mic status lights solid white.
- When in the charger, the power/mute light will be solid white.

## POWER ON THE SYSTEM AND T3 MICROPHONES

- Ensure the Redcat Access is connected to power and turned on.
- Turn on the T3 Microphones by pressing the power button for 1-2 seconds. The mic status lights will turn solid white to indicate the microphone is ready for operation.

## CONNECT T3 TO YOUR EXISTING AUDIO SYSTEM WITH ACCESS LINK

- The Access Link comes paired up to the T3 microphones and is designed to be connected into an audio input on your existing audio system.
- Place the Access Link near your existing audio amplifier.
- Using the supplied 3.5mm audio cable, plug one end into the AUDIO OUT on the Access Link and plug the other end into an audio input on our existing amplifier.
- Connect the Access Link to power using the supplied USB cable and AC adapter.
- The microphone volume level on the Access Link should be set to the mid-point, 12:00 setting.

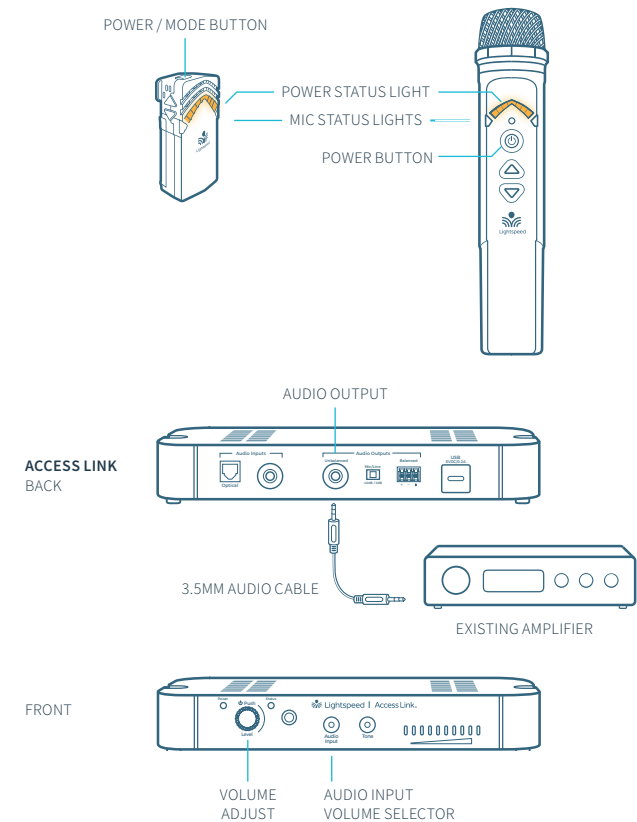



# Using T3 Microphones

## PAIRING MICROPHONES TO 955 ACCESS

 Your system is shipped with microphones and base units pre-paired for quick and easy use. If you ever need to pair new components, follow this pairing process:

**PLEASE NOTE:** Microphones should be out of the charger while pairing.

- 1 With a paperclip, push the register button on the back of the 955 Access three times in succession. The mic 1 and mic 2 lights on the 955 Access will begin flashing indicating it is in pairing mode.
- 2 To put the microphone in pairing mode: from a powered off state, press and hold the power button for five seconds until the mic 1 and mic 2 lights start flashing.
- 3 The status light on the system will glow indicating the pairing process is complete. The power status light on the microphone will glow yellow and both Mic 1 and Mic 2 lights will stay illuminated.

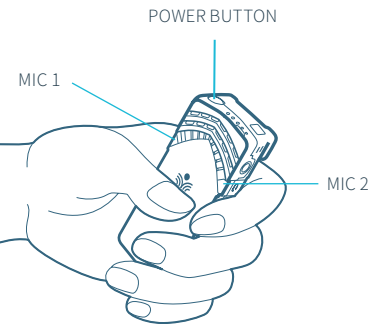

## USING YOUR T3 MICROPHONES: JUST TAP-TO-TALK

The same T3 functionality works on Flexmike and Sharemike so users can either wear them around the neck or as a hand-held pass-around microphone.

- 1 Tap the power button on a T3 microphone to begin sharing through the audio system.
  - The mode button will turn blue to indicate the microphone is broadcasting live.
- 2 To talk into different T3 microphone, just tap the power button on that microphone.
  - The mode light will turn blue.
  - The previously connected T3 will be disconnected, turning the mode light back to white.
  - To increase volume on the active T3, press the volume up button on the teacher microphone.
- 3 To mute or disconnect your T3 microphone from audio, just tap the power button again.
  - Status and power lights will turn white.

 If the microphone is out of range, it will automatically shut off after 30 minutes of trying to reconnect. When back in the classroom, press and hold the power button on the microphone to power it up.

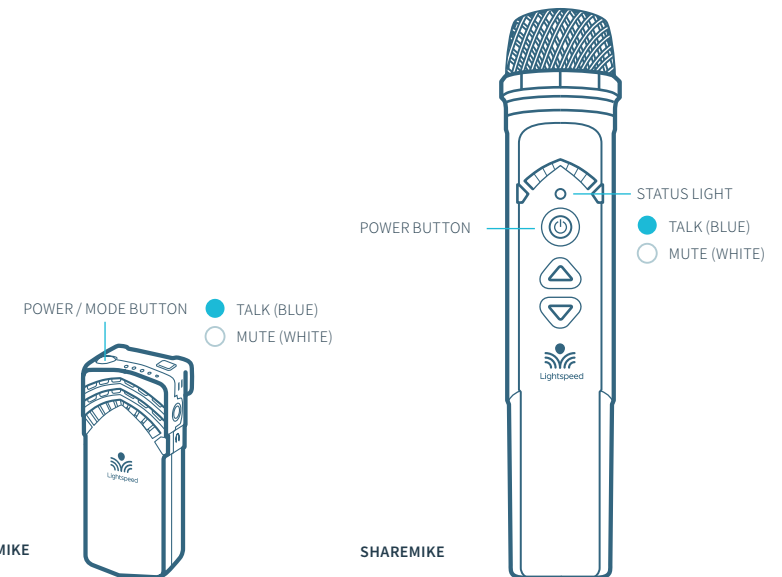



## MAINTENANCE & TROUBLESHOOTING

# Flexmike Battery Replacement

### Battery part #L3.7V

1. Push down on the latch and carefully pull the battery pack away from the Flexmike.
2. Insert new battery pack as shown and make sure the latch is secure.
3. Place the Flexmike in a cradle charger to charge the battery pack.

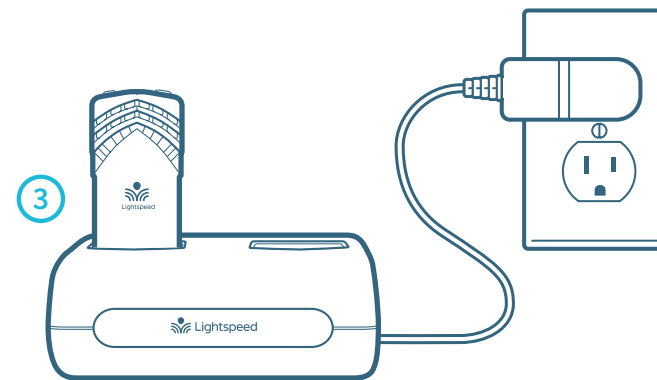
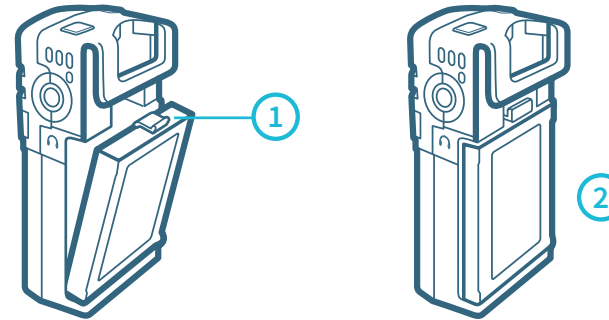



# ShareMike Battery Replacement

## Battery part #L3.7V

1. Push down on the latch and carefully pull the battery pack away from the ShareMike.
2. Insert new battery pack as shown and make sure the latch is secure.
3. Place the Flexmike in a cradle charger to charge the battery pack.

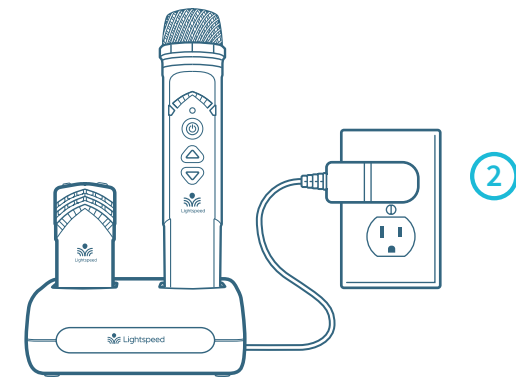
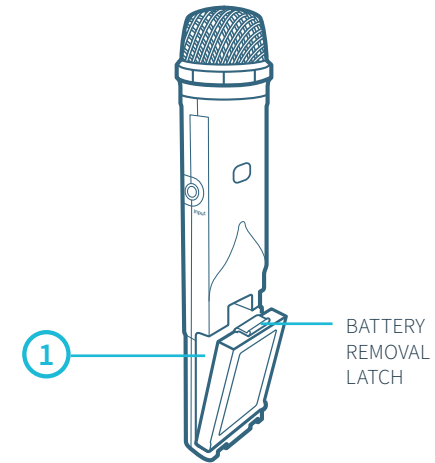



# Troubleshooting

**PROBLEM: Low battery indication:** Most problems are directly related to low battery power. Please run through the “Battery Check” items first. For remaining troubleshooting, use known good, fully-charged batteries.

**SOLUTION:** Battery Check

- Confirm batteries are charged each night. A solid red light on the battery status light indicates a low battery.
- Confirm proper batteries are used: Flexmike and Sharemike require the Lightspeed #L3.7V rechargeable battery pack.
- Make sure the microphones obtain a full charge. A full charge takes 5-6 hours.
- When charging the transmitter, the red charging light is solid. The green light will be solid when a full charge is reached.

**PROBLEM: Microphone doesn’t indicate a “Ready” signal (solid white light)**

**SOLUTION:** Follow these steps to ensure the system is ready to use.

- Ensure the power button on the microphone is turned on. Once turned on, the white light should begin blinking.
- Power the microphone off, then on again after a few seconds. Wait for up to 30 seconds for the white light to turn solid, indicating READY for operation.

**PROBLEM: Low volume or feedback**

**SOLUTION:** Follow these steps to eliminate low volume or feedback:

- If the volume is too high, feedback will occur. Adjust accordingly.
- Adjust the volume level on the Flexmike.

**PROBLEM: No sound from speaker and wireless components**

**SOLUTION:** Follow these steps to produce sound from 955 Access:

- Confirm that the blue POWER light located on the front panel of the 955 Access is on.
- Confirm the microphone is powered on and linked to the 955 Access. The Mic 1 status light will be white on the 955 Access indicating the microphone is linked.
- Confirm that the microphone is turned on. There will be a solid blue light on the top of microphone to indicate it is powered on and ready.
- Confirm that microphone is not muted. A solid white light on the top of microphone will indicate it is muted.
- Check speaker connections on the 955 Access. Make sure the cables are properly connected (see page 8 of this manual or the Installation Guide for more information).
- If a Media Connector is paired with the 955 Access, make sure that the volume level of the Activate or the Media Connector is not turned down all the way.
- Slowly turn up the volume level while talking into the microphone.

**If you still have questions after reviewing these instructions, call Lightspeed Technical Services at 800.732.8999, 5am–5pm, PST.**

Customers outside the U.S. should contact their local reseller.



# Tips for Optimum Audio Performance

- **Speak in a natural voice.** A normal conversational speech level will provide an adequate signal. It is not necessary to increase the intensity of your voice—the audio system provides adequate amplification (approximately 5–10 dB) above ambient room noises.
- Avoid **wearing jewelry** that may rub or bump against the microphone.
- **Mute the Flexmike** during private conversations with a student, parent, or other classroom visitor. You can tell the mic is muted when the light turns white.
- **Recharge microphones each night.** When recharged nightly, operating time (actual usage) for the microphones will last through a typical school day.





## WARRANTY, SAFETY & SPECIFICATIONS

### Five-Year Limited Warranty

Lightspeed Classroom Audio Systems are guaranteed against malfunction due to defects in materials and workmanship for a period of five (5) years, beginning at the date of the purchase invoice. If such malfunction occurs, the product will be repaired or replaced (at Lightspeed's option) without charge during the warranty period.

Lightspeed's Warranty Exchange Program applies to all classroom audio systems within the five (5) year warranty period. If a classroom audio product or component has an issue that requires service, a refurbished replacement will immediately be sent to the customer to minimize downtime. Customers will receive the exchange product(s) or component(s) within 2-3 days. A prepaid return label will be included with exchanged products so original malfunctioned equipment can be returned to Lightspeed. Any exchanged equipment will remain covered under the original five-year warranty.

1. Warranty on transceivers is five (5) years.
2. Warranty on Lightspeed NiMH and Lithium Polymer rechargeable batteries is one (1) year.
3. A prepaid shipping label will be provided by Lightspeed for warranty repairs within the United States. Customers outside the U.S. should refer to the Lightspeed website ([www.lightspeed-tek.com](http://www.lightspeed-tek.com)) for warranty repair instructions.
4. Warranty does not extend to finish, appearance items, or malfunctions due to abuse or operation other than specified conditions, nor does it extend to incidental or consequential damages. Repair by other than Lightspeed or its authorized service agencies will void this warranty. Information on authorized service agencies is available from Lightspeed Technologies, Inc.

**Our Service Department (800.732.8999, 5am–5pm, PST) will handle your repair or replacement needs.**

Customers outside the U.S. should contact their local reseller.



# Safety Warnings and Certifications

**CAUTION**

**RISK OF ELECTRICAL SHOCK**

**DO NOT OPEN**

**THIS PRODUCT MUST BE INSTALLED IN ACCORDANCE WITH THE APPLICABLE INSTALLATION CODE BY A PERSON FAMILIAR WITH THE CONSTRUCTION AND OPERATION OF THE PRODUCT AND THE HAZARDS INVOLVED.**

**The lightning flash** with arrowhead symbol inside an equilateral triangle is intended to alert the user to the presence of non insulated “hazardous voltage” within the product’s enclosure, which may be of sufficient magnitude to induce a risk of electric shock to persons.

**The exclamation mark** inside an equilateral triangle is intended to alert the user to the presence of important operating and maintenance (servicing) instruction in the literature accompanying this product.



**USE A LIGHTSPEED SUPPLIED BATTERY ONLY**



CAUTION: Risk of explosion if battery is replaced by an incorrect type. Dispose of used batteries according to the instructions.



Battery subjected to extremely low air pressure that may result in an explosion or the leakage of flammable liquid or gas.

## CERTIFICATIONS



This product is listed to UL standards and requirements for electrical safety by Underwriters Laboratories Inc.



This product conforms with the essential requirements of the following European Union Directives: 2004/108/EC Electromagnetic Compatibility (EMC) and 2006/95/EC Low Voltage Directive (LVD).



Lightspeed Technologies launched a formal product recycle program in Europe that complies with the European Union Directive 2002/96/EC on Waste Electrical and Electronic Equipment (“WEEE Directive”). Please visit [www.lightspeed-tek.com](http://www.lightspeed-tek.com) for more information.



This product is manufactured using lead-free processes and is free of other materials harmful to the environment. It conforms to the most stringent new European guidelines for consumer products (RoHS).



# Précautions De Sécurité et Certifications



**ATTENTION**  
**RISQUE D'ÉLECTROCUTION**  
**NE PAS OUVRIR**



**CONFORMÉMENT AUX NORMES D'INSTALLATION APPLICABLES, CE PRODUIT DOIT ÊTRE INSTALLÉ PAR UNE PERSONNE FAMILIARISÉE AVEC LA CONCEPTION ET LE FONCTIONNEMENT DU PRODUIT ET CONSCIENTE DES RISQUE ENCOURUS.**



**L'éclair flèche** dans un triangle équilatéral avertit l'utilisateur de la présence d'une "tension dangereuse" non isolée à l'intérieur de l'appareil, qui peut être d'une ampleur suffisante pour constituer un risque d'électrocution.



**Le point d'exclamation** contenu dans un triangle équilatéral avertit l'utilisateur de la présence d'importantes instructions d'exploitation et de maintenance dans la documentation qui accompagne ce produit.



UTILISEZ UNIQUEMENT LA BATTERIE LIGHTSPEED FOURNIE



ATTENTION: Risque d'explosion si la batterie est remplacée par un type incorrect. Mettre au rebut les batteries usagées selon les instructions.

## CERTIFICATIONS



Ce produit est certifié conforme aux normes et aux exigences UL en matière de sécurité électrique par Underwriters Laboratories Inc.



Ce produit est conforme aux principales exigences des directives de l'Union Européenne suivantes : 2004/108/EC Electromagnetic Compatibility (EMC) and 2006/95/EC Low Voltage Directive (LVD).



Lightspeed Technologies a lancé un programme de recyclage de produits en Europe conformément à la directive de l'Union Européenne 2002/96/CE relative aux déchets d'équipements électriques et électroniques (directive « DEEE »). Veuillez visiter notre page Web [www.Lightspeed-tek.com](http://www.Lightspeed-tek.com) pour plus de renseignements.



Ce produit est fabriqué en utilisant des processus sans plomb ni aucune autre matière nuisible à l'environnement. Il est conforme aux nouvelles règles européennes les plus strictes en matière de biens de consommation (RoHS).



# Canada, Industry Canada (IC) Notices

## English

This device complies with Industry Canada license exempt RSS standard(s). This Class B digital apparatus complies with Canadian ICES-003 and CAN ICES-3(B)/NMB-3(B). Operation is subject to the following two conditions: (1) this device may not cause interference, and (2) this device must accept any interference, including interference that may cause undesired operation of the device. The IC for this device is IC ID 1732B-LS975. This includes accessories such as the Flexmike (IC 1732B-LSFMN), Sharemike (IC 1732B-LSSMN) and Media Connector (IC 1732B-LSMCN).

## French

Canada, avis d'Industrie Canada (IC)

Cet appareil numérique de classe B est conforme aux normes canadiennes ICES-003 et RSS-247. Son fonctionnement est soumis aux deux conditions suivantes: (1) cet appareil ne doit pas causer d'interférence et (2) cet appareil doit accepter toute interférence, notamment les interférences qui peuvent affecter son fonctionnement. L'identifiant IC de cet appareil est IC ID 1732B-LS975. Ceci inclus les accessoires comme le Flexmike (IC 1732B-LSFMN), Sharemike (IC 1732B-LSSMN) et un Media Connector (IC 1732B-LSMCN).

Cet équipement est conforme aux limites d'exposition aux radiations IC inaux doivent suivre les instructions d'utilisation spécifiques pour satisfaire la conformité à l'exposition IC, veuillez suivre les instructions de fonctionnement décrites dans ce manuel.



# RF Radiation Exposure Statement

## English

Your mobile device is a radio transmitter and receiver. It is designed not to exceed the limits for exposure to radio waves (radio frequency electromagnetic fields) recommended by international guidelines. The guidelines were developed by Health Canada and include a substantial safety margin designed to assure the safety of all persons, regardless of age and health.

## French

Votre appareil mobile est un émetteur-récepteur radio. Il est conçu pour ne pas dépasser les limites d'exposition aux ondes radio (champs électromagnétiques de fréquence radio) recommandées par les directives internationales. Les lignes directrices ont été élaborées par Santé Canada et comprennent une marge de sécurité importante destinée à assurer la sécurité de toutes les personnes, indépendamment de l'âge et de la santé.

## NOTICE FOR USB

**NOTE:** Lightspeed is not responsible for any changes or modifications not expressly approved by the party responsible for compliance. Such modifications could void the user's authority to operate the equipment.

**NOTE:** This equipment has been tested and found to comply with the limits for a Class B digital device, pursuant to part 15 of the FCC Rules. These limits are designed to provide reasonable protection against harmful interference in a residential installation. This equipment generates, uses and can radiate radio frequency energy and, if not installed and used in accordance with the instructions, may cause harmful interference to radio communications. However, there is no guarantee that interference will not occur in a particular installation. If this equipment does cause harmful interference to radio or television reception, which can be determined by turning the equipment off and on, the user is encouraged to try to correct the interference by one or more of the following measures:

- Reorient or relocate the receiving antenna.
- Increase the separation between the equipment and receiver.
- Connect the equipment into an outlet on a circuit different from that to which the receiver is connected.
- Consult the dealer or an experienced radio/TV technician for help.



# System Components

## STANDARD COMPONENTS

<b>955 Access</b>	Wireless audio base station
<b>24V-2.5A-NA</b>	24V/2.5A power supply for 955 Access
<b>FSC</b>	Transceiver cradle charger, power supply
<b>5V1C</b>	5V power supply for FSC
<b>FMN</b>	Flexmike classroom transceiver with battery pack and lanyard
<b>L3.7V</b>	Lithium Polymer rechargeable battery pack for Flexmike, one per Flexmike
<b>FL</b>	Flexmike lavalier cord
<b>SPEAKERS</b>	As ordered

## STANDARD COMPONENTS (outside U.S. and Canada)

<b>955G</b>	Wireless audio base station
<b>24V-2.5A</b>	24V/2.5A power supply for 955 Access, specify country
<b>FSCG</b>	Transceiver cradle charger, power supply
<b>FMNG</b>	Flexmike classroom transceiver with battery pack and lanyard
<b>L3.7V</b>	Lithium Polymer rechargeable battery pack for Flexmike, one per Flexmike
<b>FL</b>	Flexmike lavalier cord
<b>SPEAKERS</b>	As ordered

## OPTIONAL ACCESSORIES

<b>SMN</b>	Sharemike handheld transceiver with battery pack
<b>L3.7V</b>	Lithium Polymer rechargeable battery pack for Sharemike
<b>USBC</b>	Charging cable for Sharemike
<b>EMA</b>	Earset microphone with TRRS connector for Flexmike
<b>LMA</b>	Lapel microphone with TRRS connector for Flexmike



# System Specifications

## 955 ACCESS

<b>Description</b>	Wireless audio hub
<b>Frequency response</b>	60 Hz - 7 kHz
<b>DC power input</b>	24V/2.5A
<b>Power output</b>	40 Watts total (20 W/channel)
<b>Total harmonic distortion</b>	<1% @ 10W
<b>Wireless communication</b>	Access Technology (1.9 GHz)
<b>Tone control</b>	1 bass/treble control
<b>Audio inputs</b>	Four (4) 3.5mm stereo with volume control
<b>Audio output</b>	3.5mm stereo with volume control
<b>PageFirst input</b>	Euroblock
<b>Audio Link indicators</b>	2 indicators to show link to microphone
<b>Device registration</b>	Push button for pod(s), Flexmike(s), Sharemike, Media Connector, and remote(s)
<b>Dimensions (W x H x D)</b>	7.6" x 5" x 1.13" (193 x 127 x 29mm)
<b>Weight</b>	9.6 oz. (272g)

## FLEXMIKE (1-2)

<b>Description</b>	Pendant-style transceiver
<b>Earbud lanyard</b>	Magnetic clasp with integrated earbud
<b>Wireless communication</b>	Access Technology (1.9 GHz)
<b>Audio distortion</b>	<1%
<b>Integrated microphone</b>	Uni-directional electret
<b>Earbud output</b>	3.5mm
<b>Audio input</b>	USB-C
<b>Volume control</b>	+/- 6 dB
<b>Battery power</b>	3.7V LiPo battery pack
<b>Battery life</b>	8 hours (fully charged)
<b>Charging</b>	2 contacts for cradle charging
<b>USB connection</b>	Type C for charging and audio
<b>Power</b>	On/off switch

<b>Registration</b>	Push button for registration with Access Link
<b>Dimensions (L x W x H)</b>	2.9" x 1.1" x 0.7" (74 x 28 x 18mm)
<b>Weight</b>	1.2 oz (34g)

## SHAREMIKE

<b>Description</b>	Handheld transceiver
<b>Wireless communication</b>	Access Technology (1.9 GHz)
<b>Audio distortion</b>	<1%
<b>Integrated microphone</b>	Uni-directional electret
<b>Audio input</b>	3.5mm
<b>Battery power</b>	3.7V LiPo battery pack
<b>Battery life</b>	8 hours (fully charged)
<b>Charging</b>	2 contacts for cradle charging
<b>Power</b>	On/off button
<b>Registration</b>	Push button for registration with Access Link
<b>Dimensions (L x W x H)</b>	6.0" x 1.1" x 1.1" (153 x 28 x 28mm)
<b>Weight</b>	2.6 oz (73g)

## MEDIA CONNECTOR

<b>Description</b>	Wireless audio transceiver
<b>USB power</b>	5V USB-C connector
<b>Wireless communication</b>	Access Technology (1.9 GHz)
<b>Tone control</b>	1 bass/treble control
<b>Audio input</b>	3.5mm stereo (x4) with master volume
<b>Audio output</b>	3.5mm stereo (X2) mixed with volume control
<b>Audio Link indicator</b>	1 LED on front panel
<b>Device registration</b>	Push button for Access Link
<b>Dimensions (W x H x D)</b>	7.6" x 5" x 1.13" (193 x 127 x 29mm)
<b>Weight</b>	9.6 oz. (272g)



## Dedicated to Access for All

We strive to make a remarkable difference for teachers and students by creating Access to powerful in-the-moment insights to the learning process. Our audio and video solutions improve student engagement, enable teachers to activate small groups, and encourage collaboration.

11509 SW Herman Road  
Tualatin, Oregon 97062  
Toll Free: 800.732.8999  
Phone: 503.684.5538  
Fax: 503.684.3197  
[lightspeed-tek.com](http://lightspeed-tek.com)